

**UNION TOOL**

# Tungsten Carbide End Mills UNIMAX Series

**Diamond Coated UDC Series**



**Vol.13**

Launched October 2023

**For Milling Cemented Carbide and Hard Brittle Materials**



**UNION TOOL CO.**

## Choose Union Tool for your cemented carbide milling needs.

Union Tool developed the UDC series, enabling the direct milling of cemented carbide. Since then, we have pioneered the development of diverse products that contribute to highly efficient and accurate milling. Please test and see for yourself the speed and finish that you would not expect from machining cemented carbide.



### Optimized diamond coating for cemented carbide



We developed our special high-performance diamond film for milling cemented carbide and hard brittle materials.

Hardness and durability have been dramatically increased, and further improvement has been made in wear resistance.

The adhesion to cemented carbide materials has also been improved.

### Direct “milling” of cemented carbide

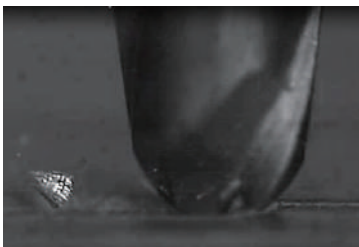

UDCB chip evacuation

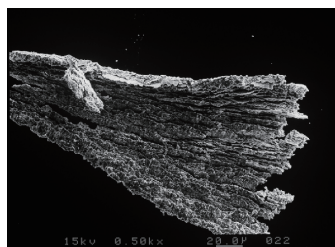

Inside view of a curled chip (surface side)

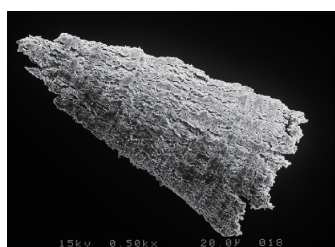

Outside view (tool/rake side)

By using a deep cut into the Cemented Carbide, UDC series creates a “fan shaped” chip, Just like cutting steel.

Various lineup available.

Please select the best tool for your application.

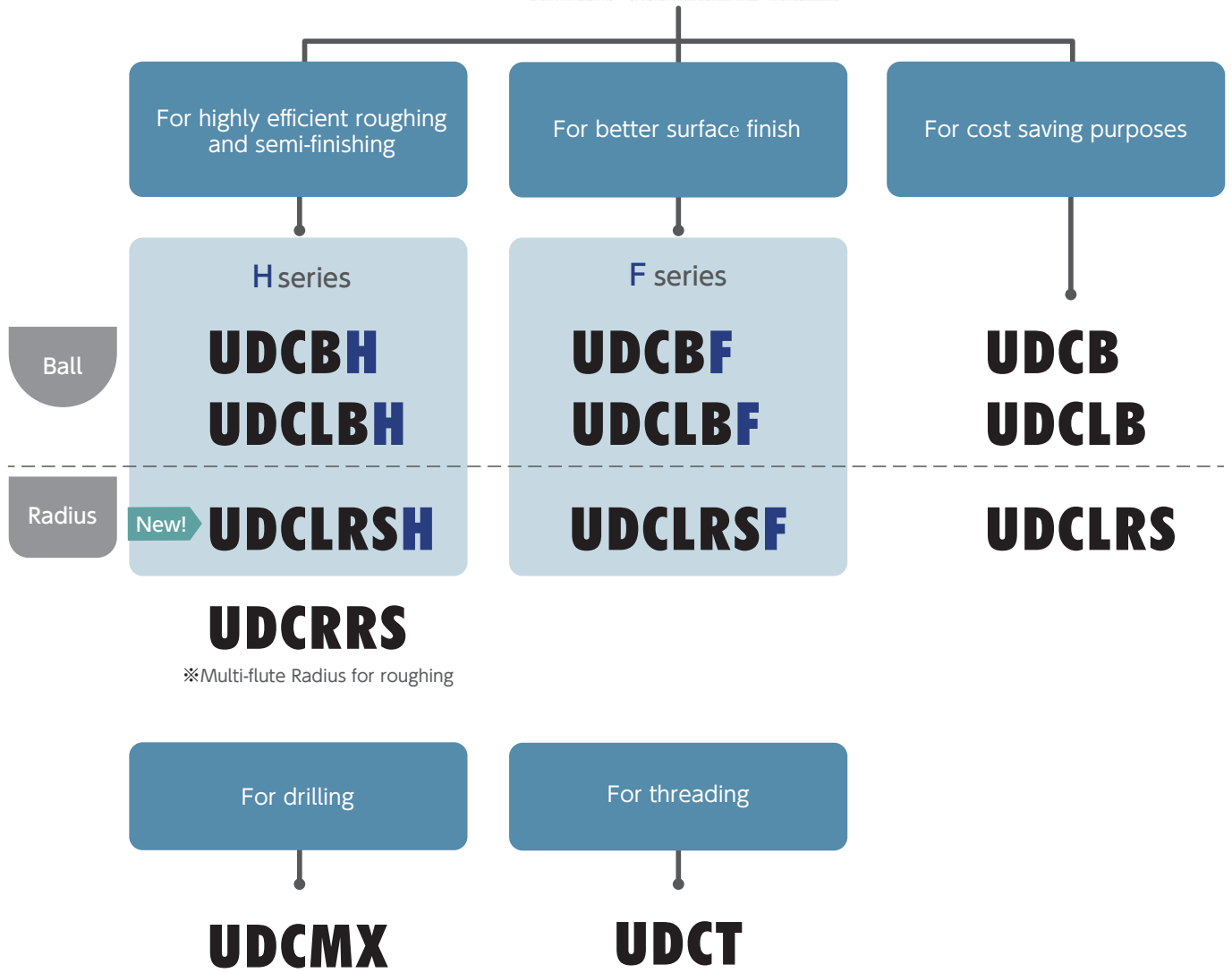

High efficiency milling with third generation UDC

# UDC-H

The best match for roughing and semi-finishing of cemented carbide.

## Features of H series

Edge treatment designed for rigidity

Unbelievable milling quality

High Speed

Mill at surprisingly high feed rate

High Removal Volume

Highly improved removal volume

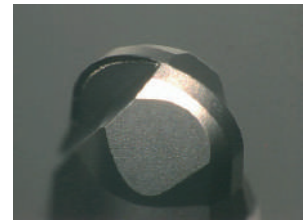

Attain both high efficiency and long tool life!

The key points ...

Tool damage minimized by edge treatment designed for rigidity





Improved diamond coating with enhanced wear resistance

More series and sizes now available!

The Long Neck Radius UDCLRSH series has been newly added to the H series. The lineup of existing series has also increased.

## UDC-H Series / Line up

Ball UDCBH	Long neck ball UDCLBH	Long neck radius UDCLRSH
		
R0.1~R3 <a href="#">Add</a>	R0.2~R3 <a href="#">Add</a>	Ø0.5~Ø2 <a href="#">New!</a>

# UDCBH

Compared to UDCBF,  
 UDCBH has.....

**7.5**  
 times the  
 efficiency

Over **4** times  
 the removal  
 volume



Lens shaped milling  
 Work Size: 50 x 50 x 10mm  
 Pocket Size: Top Ø10 x Depth 3.5mm  
 Material Removal Volume: 160mm<sup>3</sup> / Pocket  
 Coolant: Air Blow

UDCBH  
 Milling example

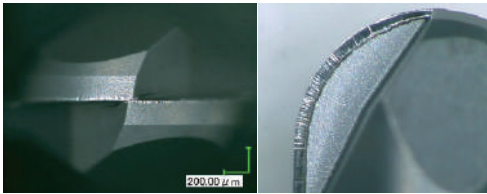
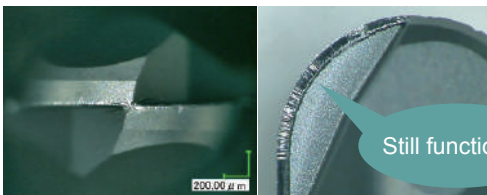

Tool	UDCBH Ball	UDCBF Ball
Milling Conditions		
Spindle Speed	30,000 min <sup>-1</sup>	20,000 min <sup>-1</sup>
Feed Rate	<b>1,500</b> mm/min	200 mm/min
$a_p$ Axial Depth	0.1 mm	
$a_e$ Radial Depth	0.3 mm	
Milling Results		
1 side 16 pockets	1 tool, Milling time 76 min	4 tools, Milling time 7 h 28 min
Tool after milling 4 pockets		
Tool after milling 16 pockets		—

※ UDCBH shows maximum tool performance under high-speed conditions.  
 Tool life may shorten when used at the same feed rate as before.

The sharpest cutting edge in the UDC series!

# UDC-F

The best choice for high quality milling surface

## F (Fine) Features of F series

- UDC Coating → Optimized coating for milling cemented carbide
- Special treatment for a sharp edge → Minimized edge chipping and the level of the gap
- Chip pocket designed on the tool tip → Excellent surface finish



Comparison of edge chipping on work piece  
**UDCBH/UDCBF R0.4 × 0.56** Cemented Carbide VM-40 (90 HRA)

Flat surface milling

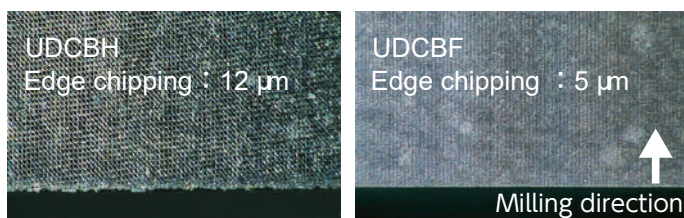

	UDCBH Ball	UDCBF Ball
Spindle Speed	30,000 min <sup>-1</sup>	
Feed Rate	750 mm/min	250 mm/min
<i>a<sub>p</sub></i> Axial Depth	0.02 mm	
<i>a<sub>e</sub></i> Radial Depth	0.02 mm	
Coolant	Air Blow	

Improve efficiency and lower costs by using the right tool to meet your edge chipping requirements

Excellent surface roughness

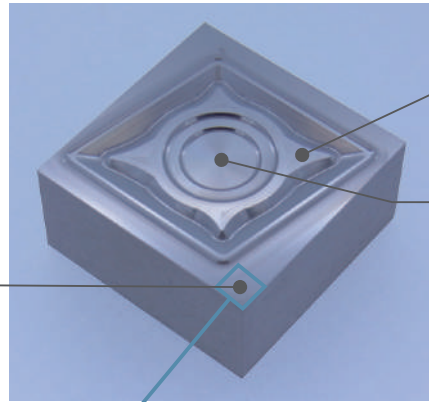

Ra: 0.054  $\mu\text{m}$   
Rz: 0.408  $\mu\text{m}$

Ra: 0.051  $\mu\text{m}$   
Rz: 0.399  $\mu\text{m}$

Ra: 0.068  $\mu\text{m}$   
Rz: 0.520  $\mu\text{m}$

Work Size : 20 × 20 × 10 mm

Minimized edge chipping

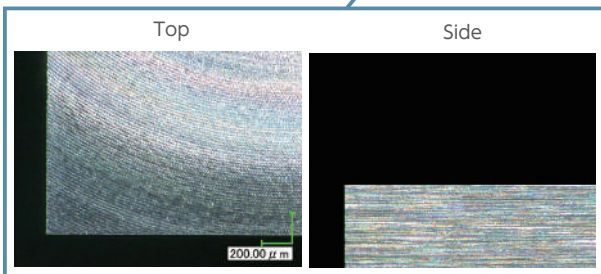

	Roughing	Finishing
Spindle Speed	30,000 min <sup>-1</sup>	
Feed Rate	300 mm/min	
$a_p$ Axial Depth	0.05 mm	0.028 mm
$a_e$ Radial Depth	0.25 mm	0.02 mm
Coolant	Air Blow	
Cycle time	43 min	2 h 17 min
Material removal volume	86.3 mm <sup>3</sup>	12.0 mm <sup>3</sup>

※ One end mill each for roughing and finishing processes.  
Total 2 tools are used.

Work Size: 20 x 20 x 10mm

Slot Size: W 2 x D 1.99mm

	UDCLRS Long Neck Radius	UDCLRSF Long Neck Radius
Work Material		
Rake Face		
	After 4 slots	After 5 slots
Relief		
	After 4 slots Corner Radius damage	After 5 slots More tool life left

	UDCLRS Long Neck Radius	UDCLRSF Long Neck Radius
Spindle Speed	20,000 min <sup>-1</sup>	
Feed Rate	375 mm/min	190 mm/min
$a_p$ Axial Depth	0.02 mm	0.06 mm
Coolant	Air Blow	
Cycle time (Per slot)	9 min 4 sec	5 min 36 sec
Material removal volume	352 mm <sup>3</sup>	440 mm <sup>3</sup>

# UDCRRS

For roughing large  $a_p$  area

Designed for high efficiency milling

6 Flutes, 10 Flutes with a 40° helix angle help to reduce cutting load allowing for deep milling on axial depth.

Ø2 ~ Ø4  
6 Flutes

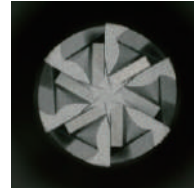

Ø6  
10 Flutes

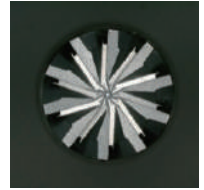

Milling amount compared with 2 Flutes (Ø2 × EL 6)

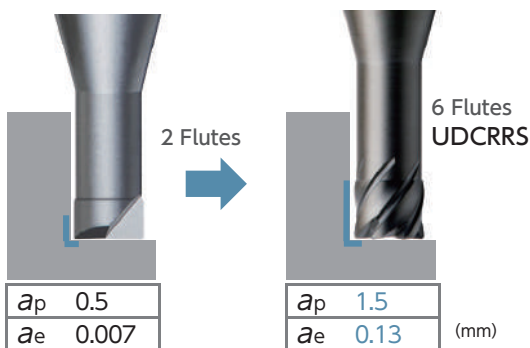

Compared to a tool with 2 flutes, the  $a_p$  is 3 times and the  $a_e$  is 18 times higher.

This shows a significant efficiency improvement.

Cutting material removal volume for each size

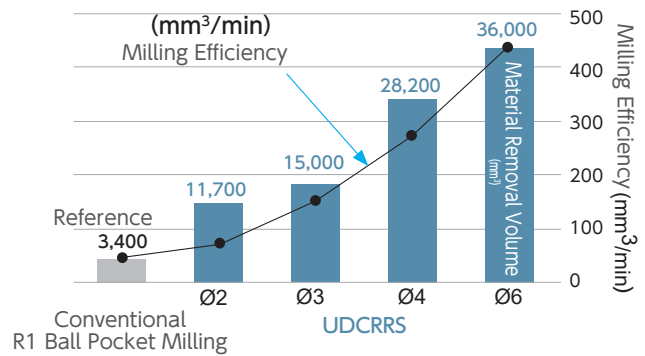

Milling efficiency and material removal volume exceeds the conventional tool.

Punching die milling  
UDCRRS Ø4 × CR0.2 × EL10

Cemented Carbide  
VM-40 (90 HRA)

Spindle Speed	15,000 min <sup>-1</sup>
Feed Rate	375 mm/min
$a_p$ Axial Depth	3 mm
$a_e$ Radial Depth	0.25 mm
Coolant	Air Blow
Cycle Time	93 min

Depth 9 mm  
 $a_p$  3 mm × 3 times

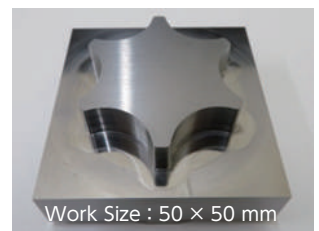
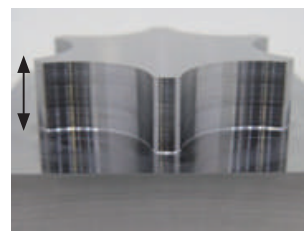

Tool after milling



Milling volume **15,953 mm<sup>3</sup>** with a single tool in **93 min**.  
Tool damage is limited and continuous cutting is possible.



Part shaped milling

Cemented Carbide  
**VM-40 (90 HRA)**

UDCLBH R0.2  
After milling

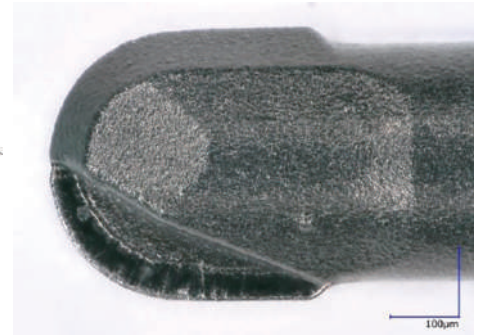
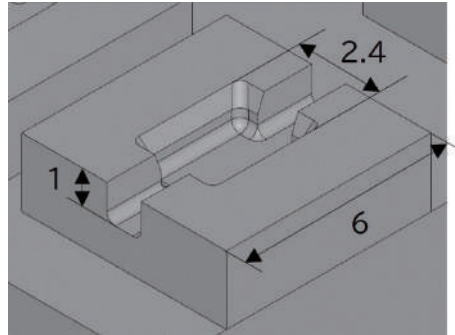
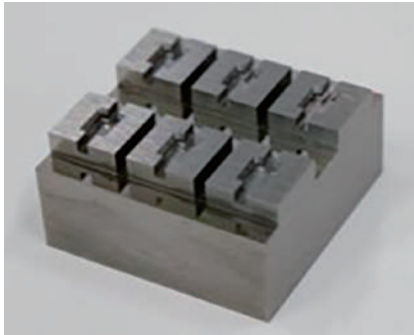

Block Size : 6 × 6 × h2 mm

Process	Tool	Spindle Speed (min <sup>-1</sup> )	Feed Rate (mm/min)	a <sub>p</sub> Axial Depth (mm)	a <sub>e</sub> Radial Depth (mm)	Allowance (mm)	Cycle Time (h:m)
Roughing	UDCLBH (Long Neck Ball) R0.3 × EL1	30,000	600	0.03	0.14	0.02	1:04
Semi-finishing	UDCLBH (Long Neck Ball) R0.2 × EL1	30,000	300	0.015	0.04	0.005	0:47
Finishing	UDCLBF (Long Neck Ball) R0.2 × EL1	30,000	100	0.028	0.028	0	1:42
Total							5:14

※ For 6 blocks

Drilling and Threading

Cemented Carbide  
**VM-40 (90 HRA)**

Drills and thread mills are also available.

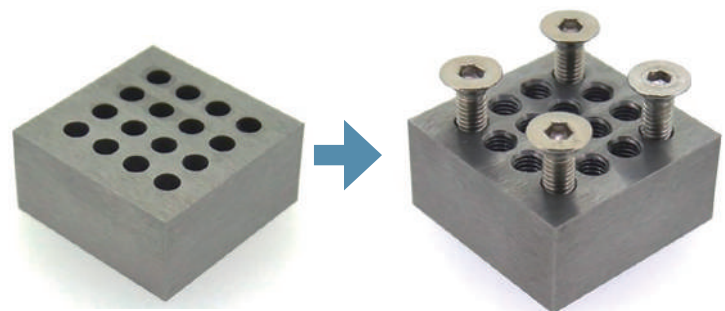
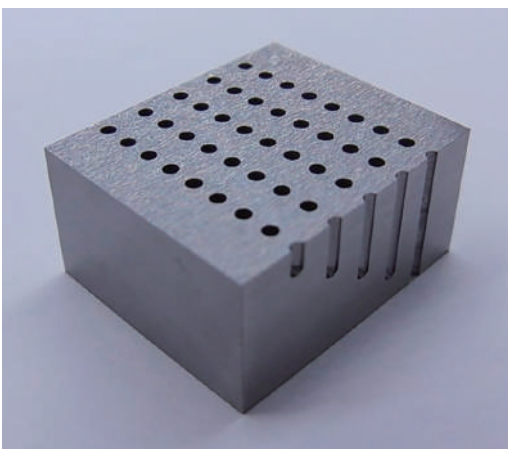

Tool :UDCMX (∅2.5 × 10)

UDCT (M3 × L6 P0.5)

Work : VM-40 (90 HRA)



Tool: UDCMX 2100-100 (∅1 × 10)  
Work: VM-40 (90 HRA)

Scan here for other milling examples.



### Not just for cemented carbide

UDC series is also suited for ceramics (hard brittle materials).

Examples of ceramics (hard brittle materials)

$Al_2O_3$   
Alumina

$ZrO_2$   
Zirconia

AlN  
Aluminum Nitride

Electronic component assembly jig shaped milling

Alumina  
Zirconia

Work material: Alumina  $Al_2O_3$  (99.5%), Zirconia  $ZrO_2$  (94%)

Work Size: 30 x 20 x 10mm

Coolant: Water soluble (Wet type is recommended for both materials.)

Alumina

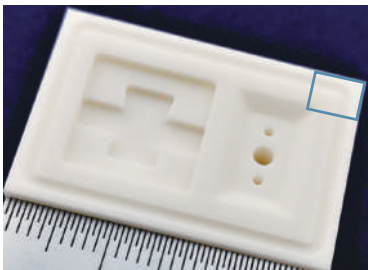

Zirconia

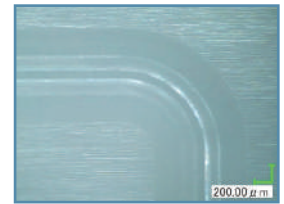
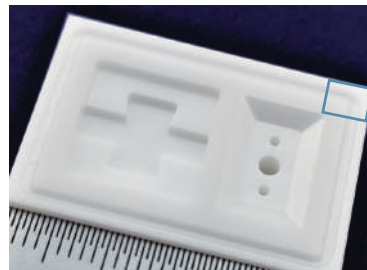

Process	Tool	Spindle Speed (min <sup>-1</sup> )	Feed Rate (mm/min)	$a_p$ Axial Depth (mm)	$a_e$ Radial Depth (mm)	Allowance (mm)	Cycle Time (h:m:s)
Slotting & inclined pocket roughing	UDCBH (Ball) R0.5 × L0.7	30,000	300	0.05	0.25	0.01/0.03	0:36:29
Slot finishing						0	0:19:17
2-stage pocket roughing	UDCLBF (Long Neck Ball) R0.5 × EL2	30,000	300	0.028	0.028	0.03	0:52:42
Corner removal	UDCLRSF (Long Neck Radius) Ø0.8 × CR0.05 × EL2.4	30,000	175	0.023	0.5	0.03	0:18:26
Semi-finishing				0.02	0.25	0.01	0:51:09
Finishing				0.014	0.25	0	1:12:32
Drilling	UDCMX (Drill) Ø2 × FL10	2,400	5	0.15	—	—	0:03:15
Drilling	UDCMX (Drill) Ø1 × FL10	5,000	7.5	0.05	—	—	0:10:44

Total 4:24:34

# Available not only for cemented carbide molds and also for a wide range of work materials.

High-capacity pocket + Drilling

Alumina

Work material: Alumina Al<sub>2</sub>O<sub>3</sub> (99.5%)

Coolant: Water soluble

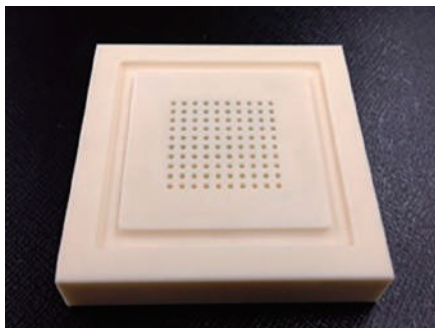

Enlarged peripheral pocket

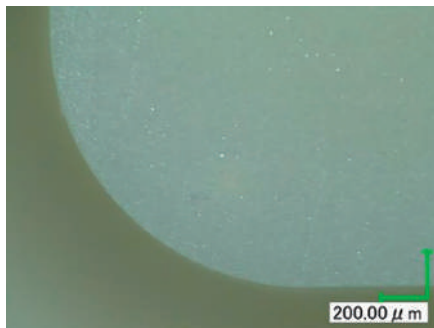

Enlarged 100th hole

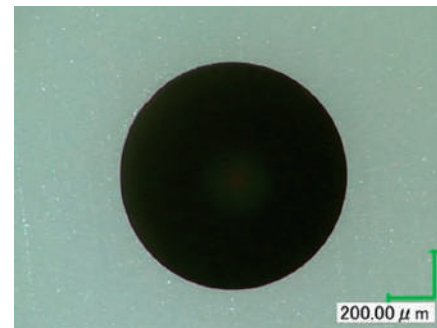

Minimized edge chipping!

Milled parts	Tool	Spindle Speed (min <sup>-1</sup> )	Feed Rate (mm/min)	a <sub>p</sub> Axial Depth (mm)	a <sub>e</sub> Radial Depth (mm)	Peck amount (mm)	Cycle Time (h:m)	M.R.V. (mm <sup>3</sup> )
Peripheral pocket	UDCBF (Ball) R1 × 1.4	20,000	200	0.1	0.3	—	1:14	600
9 mm Blind holes	UDCMX (Drill) Ø1 × FL 10	5,000	8	—	—	0.05	8:46	695

**POINT!** Recommend water soluble coolant for milling ceramics.

Milling condition

Tool: UDCLBF (Long Neck Ball)  
R0.5 × EL10

Work material: Alumina Al<sub>2</sub>O<sub>3</sub> (99.5%)

Coolant: 3 types (below)

Spindle Speed (min <sup>-1</sup> )	Feed Rate (mm/min)	a <sub>p</sub> Axial Depth (mm)	a <sub>e</sub> Radial Depth (mm)
10,000	100	0.018	0.03

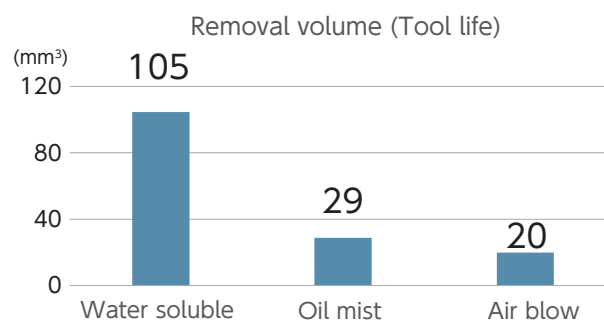

Tool damage after 18 mm<sup>3</sup> milling



Water soluble



Oil mist



Air blow

Minimized wear and longer tool life with water soluble coolant.

Milling example



### Characteristics of cemented carbide

Characteristics (= Processability) differ by the type of cemented carbide.  
Relationship between particle size and hardness.

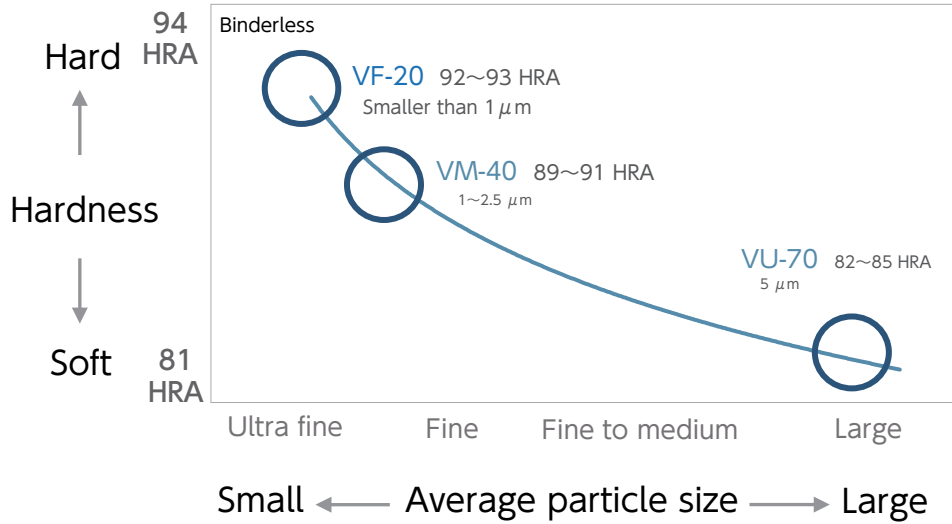

### Removal volume and cemented carbide

We recommend that you select a material with workability while considering the required performance (Ex. Mold life).

#### Milling condition

Tool: UDCB (Ball) R0.5 x L0.7

Work material: Cemented carbide (below)

Coolant: Oil mist

Spindle Speed (min <sup>-1</sup> )	Feed Rate (mm/min)	a <sub>p</sub> Axial Depth (mm)	a <sub>e</sub> Radial Depth (mm)
30,000	300	0.1	0.05

WC	Symbol	Density (g/cm <sup>3</sup> )	Hardness (HRA)	Anti breaking force (MPa)	Compressive strength (MPa)	Co amount* (MPa)	Particle size (μm)	Removal volume (①= 100%)
①	VF-20	14.1	92.5 ~ 93.0	4,500 ~ 5,000	—	12	0.5	100%
②	VM-40	14.7	90	3,240	4,700	8.8	2 ~ 3	59%
③	VM-40	14.3	89	3,400	—	13.6	—	34%
④	VM-50	14.2	87.5	3,160	4,070	15.1	—	50%
⑤	—	13.1	83	2,660	2,800	28.9	—	17%

\*in-house measurement The ratio varies depending on the series and tool shapes.

# Tips for effective use

## Coolant

We recommend air blow for milling cemented carbide.

### Milling condition

Tool: UDCB (Ball) R0.5 x L0.7

Work material: VM-40 Cemented carbide

Coolant: 3 types (below)

Spindle Speed (min <sup>-1</sup> )	Feed Rate (mm/min)	a <sub>p</sub> Axial Depth (mm)	a <sub>e</sub> Radial Depth (mm)
30,000	300	0.1	0.05

Tool damage after 30 mm<sup>3</sup> milling

Water soluble



Oil mist

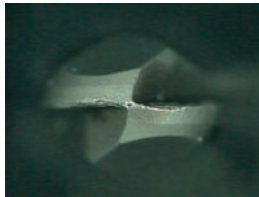

Air blow

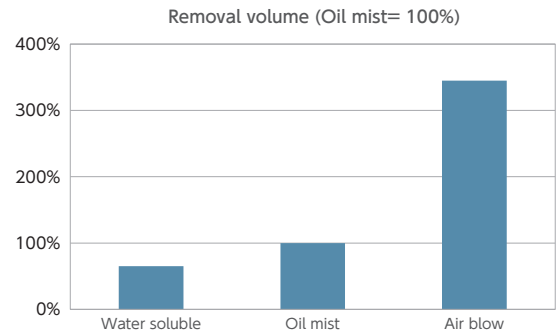
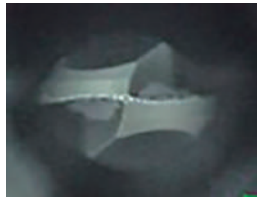

## Setting feed rate of Approach and Connection links

Feed Rate2 in the milling conditions are for Approach and Connection links where the cutting load is high.

Spindle Speed (min <sup>-1</sup> )	Feed Rate (mm/min)	※Feed Rate 2 (mm/min)
30,000	200	20
30,000	250	25
30,000	450	45

### ◆ Approach

When tool contact the work

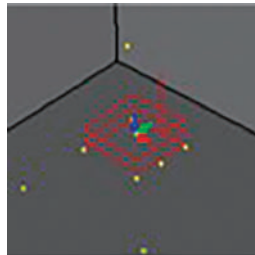

### ◆ Connection links

Movement when tool across the passed area

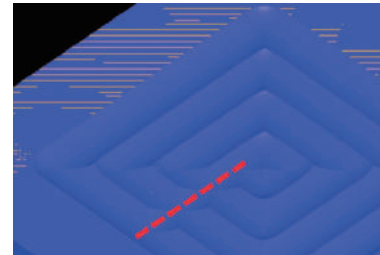

Slope or helical is recommended for the approach, but tool damage may vary depending on the operation.

Inclined approach

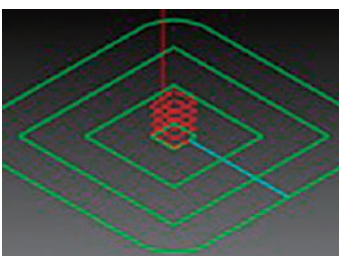

Helical approach

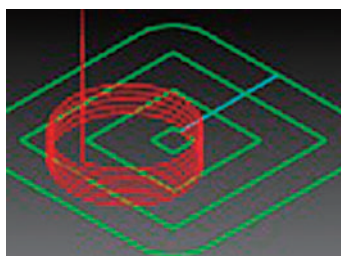

Scan here for more information on how to use UDC



# UDCBH

Additional  
4 models



2 Flute High-speed Ball End Mills for Cemented Carbide and Hard Brittle Materials

R0.1 ~ R3



Material Applications (★ Highly Recommended ● Recommended ○ Suggested)

Work Material																	
CARBON STEELS S45C S55C	ALLOY STEELS SK / SCM SUS	PREHARDENED STEELS NAK HPM	HARDENED STEELS					CAST IRON	ALUMINUM ALLOYS	GRAPHITE	COPPER	PLASTICS	GLASS FILLED PLASTICS	TITANIUM ALLOYS	HEAT RESISTANT ALLOYS	CEMENTED CARBIDE	HARD BRITTLE (NON-METALLIC) MATERIALS
			~ 50 HRC	~ 55 HRC	~ 60 HRC	~ 65 HRC	~ 70 HRC										
												○			★	●	

※Hard Brittle (Non-Metallic) Materials: Ceramics (Alumina, Zirconia, etc.), Glasses and etc.



For high efficiency roughing and semi-finishing

Label Sample



#001 ØD1.997 R+0.001/-0.001

Diameter and Ball Radius accuracy measurements are printed on the label to support High Precision milling.

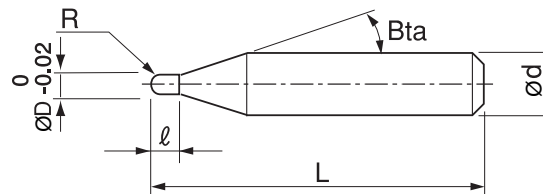

The shank taper angle shown is not an exact value.

Total 14 models

Unit (mm)

Model Number	Radius of Ball Nose R	Length of Cut ℓ	Shank Taper Angle Bta	Overall Length L	Shank Diameter ød	Series
UDCBH 2002-0014	R0.1	0.14	16°	50	4	UDCBH
UDCBH 2003-0021	R0.15	0.21	16°	50	4	UDCBH
UDCBH 2004-0028	R0.2	0.28	16°	50	4	UDCBH
UDCBH 2005-0035	R0.25	0.35	16°	50	4	UDCBH
UDCBH 2006-0042	R0.3	0.42	16°	50	4	UDCBH
UDCBH 2007-0049	R0.35	0.49	16°	50	4	UDCBH
UDCBH 2008-0056	R0.4	0.56	16°	50	4	UDCBH
UDCBH 2010-0070	R0.5	0.7	16°	50	4	UDCBH
UDCBH 2015-0105	R0.75	1.05	16°	50	4	UDCBH
UDCBH 2020-0140	R1	1.4	16°	50	4	UDCBH
※ UDCBH 2030-0210	R1.5	2.1	16°	60	6	UDCBH
※ UDCBH 2040-0280	R2	2.8	16°	60	6	UDCBH
※ UDCBH 2050-0350	R2.5	3.5	16°	60	6	UDCBH
※ UDCBH 2060-0420	R3	4.2	—	60	6	UDCBH

※Additional model

WORK MATERIAL			CEMENTED CARBIDE (≥87 HRA)					CEMENTED CARBIDE (<87 HRA)					HARD BRITTLE MATERIALS				
Model Number	Radius of Ball Nose (mm)	Length of Cut (mm)	Spindle Speed (min <sup>-1</sup> )	Feed Rate (mm/min)	*Feed Rate2 (mm/min)	a <sub>p</sub> Axial Depth (mm)	a <sub>e</sub> Radial Depth (mm)	Spindle Speed (min <sup>-1</sup> )	Feed Rate (mm/min)	*Feed Rate2 (mm/min)	a <sub>p</sub> Axial Depth (mm)	a <sub>e</sub> Radial Depth (mm)	Spindle Speed (min <sup>-1</sup> )	Feed Rate (mm/min)	*Feed Rate2 (mm/min)	a <sub>p</sub> Axial Depth (mm)	a <sub>e</sub> Radial Depth (mm)
2002-0014	R0.1	0.14	30,000	200	20	0.008	0.008	30,000	200	20	0.008	0.008	30,000	100	10	0.01	0.01
2003-0021	R0.15	0.21	30,000	250	25	0.012	0.024	30,000	250	25	0.024	0.012	30,000	125	13	0.015	0.03
2004-0028	R0.2	0.28	30,000	450	45	0.02	0.08	30,000	600	60	0.08	0.02	30,000	150	15	0.02	0.08
2005-0035	R0.25	0.35	30,000	525	53	0.025	0.11	30,000	700	70	0.11	0.025	30,000	175	18	0.025	0.11
2006-0042	R0.3	0.42	30,000	600	200	0.03	0.14	30,000	900	300	0.17	0.03	30,000	200	20	0.03	0.14
2007-0049	R0.35	0.49	30,000	690	230	0.035	0.17	30,000	1,050	350	0.18	0.035	30,000	225	23	0.035	0.17
2008-0056	R0.4	0.56	30,000	750	250	0.04	0.19	30,000	1,250	420	0.19	0.04	30,000	250	25	0.04	0.19
2010-0070	R0.5	0.7	30,000	900	300	0.05	0.22	25,000	1,300	430	0.2	0.05	30,000	300	30	0.05	0.25
2015-0105	R0.75	1.05	30,000	1,200	400	0.075	0.27	19,000	1,450	480	0.23	0.07	24,000	400	45	0.075	0.27
2020-0140	R1	1.4	30,000	1,500	500	0.1	0.3	16,500	1,600	530	0.25	0.1	18,000	600	200	0.1	0.3
2030-0210	R1.5	2.1	24,000	1,200	400	0.1	0.3	9,000	280	140	0.38	0.15	20,000	200	100	0.15	0.3
2040-0280	R2	2.8	18,000	900	300	0.125	0.325	7,200	280	140	0.5	0.5	18,000	180	90	0.175	0.32
2050-0350	R2.5	3.5	12,000	600	200	0.175	0.37	6,000	330	170	0.6	0.25	16,000	160	80	0.225	0.31
2060-0420	R3	4.2	9,000	500	166	0.2	0.4	5,500	280	140	0.65	0.28	15,000	150	75	0.3	0.3

\*Feed Rate2: Feed rate of approach and \*connection moves.

\*Changing from one engagement point to the next.

Equivalent to UDCBF conditions

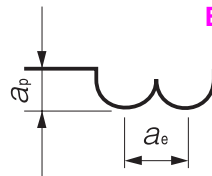

# UDCBF



2 Flute High-grade Ball End Mills for Cemented Carbide and Hard Brittle Materials

R0.1 ~ R3



Material Applications (★ Highly Recommended ● Recommended ○ Suggested)

Work Material																	
CARBON STEELS S45C S55C	ALLOY STEELS SK / SCM SUS	PREHARDENED STEELS NAK HPM	HARDENED STEELS					CAST IRON	ALUMINUM ALLOYS	GRAPHITE	COPPER	PLASTICS	GLASS FILLED PLASTICS	TITANIUM ALLOYS	HEAT RESISTANT ALLOYS	CEMENTED CARBIDE	HARD BRITTLE (NON-METALLIC) MATERIALS
			~ 50 HRC	~ 55 HRC	~ 60 HRC	~ 65 HRC	~ 70 HRC										
												○			★	●	

※Hard Brittle (Non-Metallic) Materials: Ceramics (Alumina, Zirconia, etc.), Glasses and etc.



For excellent surface quality

Label Sample



#001 ØD0.797 R+0.003/0.000

Diameter and Ball Radius accuracy measurements are printed on the label to support High Precision milling.

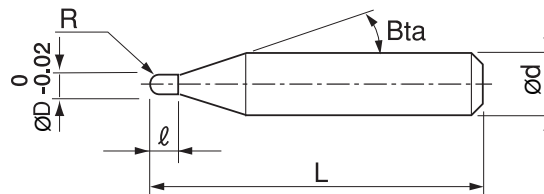

The shank taper angle shown is not an exact value.

Total 17 models

Unit (mm)

Model Number	Radius of Ball Nose R	Length of Cut ℓ	Shank Taper Angle Bta	Overall Length L	Shank Diameter Ød	Series
UDCBF 2002-0014	R0.1	0.14	16°	50	4	UDCBF
UDCBF 2003-0021	R0.15	0.21	16°	50	4	UDCBF
UDCBF 2004-0028	R0.2	0.28	16°	50	4	UDCBF
UDCBF 2005-0035	R0.25	0.35	16°	50	4	UDCBF
UDCBF 2006-0042	R0.3	0.42	16°	50	4	UDCBF
UDCBF 2007-0049	R0.35	0.49	16°	50	4	UDCBF
UDCBF 2008-0056	R0.4	0.56	16°	50	4	UDCBF
UDCBF 2009-0063	R0.45	0.63	16°	50	4	UDCBF
UDCBF 2010-0070	R0.5	0.7	16°	50	4	UDCBF
UDCBF 2012-0084	R0.6	0.84	16°	50	4	UDCBF
UDCBF 2015-0105	R0.75	1.05	16°	50	4	UDCBF
UDCBF 2020-0140	R1	1.4	16°	50	4	UDCBF
UDCBF 2025-0175	R1.25	1.75	16°	50	4	UDCBF
UDCBF 2030-0210	R1.5	2.1	16°	60	6	UDCBF
UDCBF 2040-0280	R2	2.8	16°	60	6	UDCBF
UDCBF 2050-0350	R2.5	3.5	16°	60	6	UDCBF
UDCBF 2060-0420	R3	4.2	—	60	6	UDCBF



WORK MATERIAL			CEMENTED CARBIDE ( $\geq 87$ HRA) / HARD BRITTLE MATERIALS					CEMENTED CARBIDE ( $< 87$ HRA)				
Model Number	Radius of Ball Nose (mm)	Length of Cut (mm)	Spindle Speed (min <sup>-1</sup> )	Feed Rate (mm/min)	*Feed Rate2 (mm/min)	$a_p$ Axial Depth (mm)	$a_e$ Radial Depth (mm)	Spindle Speed (min <sup>-1</sup> )	Feed Rate (mm/min)	*Feed Rate2 (mm/min)	$a_p$ Axial Depth (mm)	$a_e$ Radial Depth (mm)
2002-0014	R0.1	0.14	30,000	100	10	0.01	0.01	30,000	100	10	0.01	0.01
2003-0021	R0.15	0.21	30,000	125	13	0.015	0.03	30,000	125	13	0.015	0.03
2004-0028	R0.2	0.28	30,000	150	15	0.02	0.08	30,000	150	15	0.02	0.08
2005-0035	R0.25	0.35	30,000	175	18	0.025	0.11	30,000	175	18	0.025	0.11
2006-0042	R0.3	0.42	30,000	200	20	0.03	0.14	30,000	200	20	0.03	0.14
2007-0049	R0.35	0.49	30,000	225	23	0.035	0.17	30,000	225	23	0.035	0.17
2008-0056	R0.4	0.56	30,000	250	25	0.04	0.19	30,000	250	25	0.04	0.19
2009-0063	R0.45	0.63	30,000	275	28	0.045	0.22	30,000	275	28	0.045	0.22
2010-0070	R0.5	0.7	30,000	300	30	0.05	0.25	30,000	300	150	0.35	0.075
2012-0084	R0.6	0.84	27,500	275	36	0.06	0.26	25,000	250	125	0.42	0.09
2015-0105	R0.75	1.05	25,000	250	45	0.075	0.27	19,000	190	95	0.525	0.12
2020-0140	R1	1.4	20,000	200	60	0.1	0.3	12,500	125	60	0.7	0.15
2025-0175	R1.25	1.75	20,000	200	60	0.12	0.3	10,000	100	50	0.8	0.18
2030-0210	R1.5	2.1	20,000	200	100	0.15	0.3	9,000	280	140	0.38	0.15
2040-0280	R2	2.8	18,000	180	90	0.175	0.32	7,200	280	140	0.5	0.2
2050-0350	R2.5	3.5	16,000	160	80	0.225	0.31	6,000	330	170	0.6	0.25
2060-0420	R3	4.2	15,000	150	75	0.3	0.3	5,500	280	140	0.65	0.28

\*Feed Rate2: Feed rate of approach and \*connection moves.

\*Changing from one engagement point to the next.

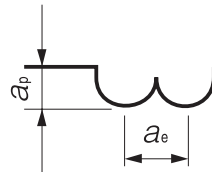

# UDCB



2 Flute Ball End Mills for Cemented Carbide and Hard Brittle Materials

## R0.1 ~ R3



Material Applications (★ Highly Recommended ● Recommended ○ Suggested)

Work Material																	
CARBON STEELS S45C S55C	ALLOY STEELS SK / SCM SUS	PREHARDENED STEELS NAK HPM	HARDENED STEELS					CAST IRON	ALUMINUM ALLOYS	GRAPHITE	COPPER	PLASTICS	GLASS FILLED PLASTICS	TITANIUM ALLOYS	HEAT RESISTANT ALLOYS	CEMENTED CARBIDE	HARD BRITTLE (NON-METALLIC) MATERIALS
			~ 50 HRC	~ 55 HRC	~ 60 HRC	~ 65 HRC	~ 70 HRC										
												○ ※1			★	● ※2	

※ 1 DCB / DCBL series are highly recommended for Glass Filled Plastic milling.

※ 2 Hard Brittle (Non-Metallic) Materials: Ceramics (Alumina, Zirconia, etc.), Glasses and etc.

Entry Series

For low-cost milling

Label Sample



#001 ØD1.983 R0.00/-0.005

Diameter and Ball Radius accuracy measurements are printed on the label to support High Precision milling.

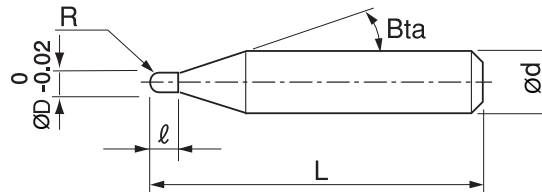

The shank taper angle shown is not an exact value.

Total 14 models

Unit (mm)

Model Number	Radius of Ball Nose R	Length of Cut ℓ	Shank Taper Angle Bta	Overall Length L	Shank Diameter Ød	Series
UDCB 2002-0014	R0.1	0.14	16°	50	4	UDCB
UDCB 2003-0021	R0.15	0.21	16°	50	4	UDCB
UDCB 2004-0028	R0.2	0.28	16°	50	4	UDCB
UDCB 2005-0035	R0.25	0.35	16°	50	4	UDCB
UDCB 2006-0042	R0.3	0.42	16°	50	4	UDCB
UDCB 2007-0049	R0.35	0.49	16°	50	4	UDCB
UDCB 2008-0056	R0.4	0.56	16°	50	4	UDCB
UDCB 2009-0063	R0.45	0.63	16°	50	4	UDCB
UDCB 2010-0070	R0.5	0.7	16°	50	4	UDCB
UDCB 2020-0140	R1	1.4	16°	50	4	UDCB
UDCB 2030-0210	R1.5	2.1	16°	60	6	UDCB
UDCB 2040-0280	R2	2.8	16°	60	6	UDCB
UDCB 2050-0350	R2.5	3.5	16°	60	6	UDCB
UDCB 2060-0420	R3	4.2	—	60	6	UDCB

WORK MATERIAL			CEMENTED CARBIDE (≥ 87 HRA)					CEMENTED CARBIDE (< 87 HRA)					HARD BRITTLE MATERIALS				
Model Number	Radius of Ball Nose (mm)	Length of Cut (mm)	Spindle Speed (min <sup>-1</sup> )	Feed Rate (mm/min)	*Feed Rate2 (mm/min)	a <sub>p</sub> Axial Depth (mm)	a <sub>e</sub> Radial Depth (mm)	Spindle Speed (min <sup>-1</sup> )	Feed Rate (mm/min)	*Feed Rate2 (mm/min)	a <sub>p</sub> Axial Depth (mm)	a <sub>e</sub> Radial Depth (mm)	Spindle Speed (min <sup>-1</sup> )	Feed Rate (mm/min)	*Feed Rate2 (mm/min)	a <sub>p</sub> Axial Depth (mm)	a <sub>e</sub> Radial Depth (mm)
2002-0014	R0.1	0.14	30,000	100	10	0.01	0.01	30,000	100	10	0.01	0.01	30,000	100	10	0.01	0.01
2003-0021	R0.15	0.21	30,000	125	13	0.015	0.03	30,000	125	13	0.015	0.03	30,000	125	13	0.015	0.03
2004-0028	R0.2	0.28	30,000	150	15	0.02	0.08	30,000	150	15	0.02	0.08	30,000	150	15	0.02	0.08
2005-0035	R0.25	0.35	30,000	175	18	0.025	0.11	30,000	175	18	0.025	0.11	30,000	175	18	0.025	0.11
2006-0042	R0.3	0.42	30,000	200	20	0.03	0.14	30,000	200	20	0.03	0.14	30,000	200	20	0.03	0.14
2007-0049	R0.35	0.49	30,000	225	23	0.035	0.17	30,000	225	23	0.035	0.17	30,000	225	23	0.035	0.17
2008-0056	R0.4	0.56	30,000	250	25	0.04	0.19	30,000	250	25	0.04	0.19	30,000	250	25	0.04	0.19
2009-0063	R0.45	0.63	30,000	275	28	0.045	0.22	30,000	275	28	0.045	0.22	30,000	275	28	0.045	0.22
2010-0070	R0.5	0.7	30,000	300	30	0.05	0.25	20,000	400	200	0.35	0.075	30,000	300	30	0.05	0.25
2020-0140	R1	1.4	30,000	300	100	0.1	0.3	16,500	420	210	0.25	0.1	24,000	240	100	0.1	0.3
2030-0210	R1.5	2.1	27,500	275	140	0.125	0.33	11,000	280	140	0.38	0.15	24,000	240	120	0.125	0.33
2040-0280	R2	2.8	24,000	240	120	0.15	0.35	8,250	300	150	0.5	0.2	24,000	240	120	0.15	0.35
2050-0350	R2.5	3.5	22,000	220	110	0.175	0.37	6,600	330	160	0.6	0.25	22,000	220	110	0.175	0.37
2060-0420	R3	4.2	20,000	200	100	0.2	0.4	5,500	280	140	0.65	0.28	20,000	200	100	0.2	0.4

\*Feed Rate2: Feed rate of approach and \*connection moves.

\*Changing from one engagement point to the next.

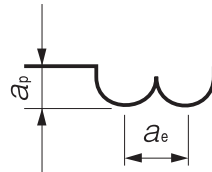

# UDCLBH

Additional  
7 models



2 Flute High-speed Long Neck Ball End Mills for Cemented Carbide and Hard Brittle Materials

R0.2~R3



Material Applications (★ Highly Recommended ● Recommended ○ Suggested)

Work Material																	
CARBON STEELS S45C S55C	ALLOY STEELS SK / SCM SUS	PREHARDENED STEELS NAK HPM	HARDENED STEELS					CAST IRON	ALUMINUM ALLOYS	GRAPHITE	COPPER	PLASTICS	GLASS FILLED PLASTICS	TITANIUM ALLOYS	HEAT RESISTANT ALLOYS	CEMENTED CARBIDE	HARD BRITTLE (NON-METALLIC) MATERIALS
			~ 50 HRC	~ 55 HRC	~ 60 HRC	~ 65 HRC	~ 70 HRC										
												○			★	●	

※Hard Brittle (Non-Metallic) Materials: Ceramics (Alumina, Zirconia, etc.), Glasses and etc.



Series

For high efficiency roughing and semi-finishing

Label Sample



#001 ØD1.989 R0.001/-0.002

Diameter and Ball Radius accuracy measurements are printed on the label to support High Precision milling.

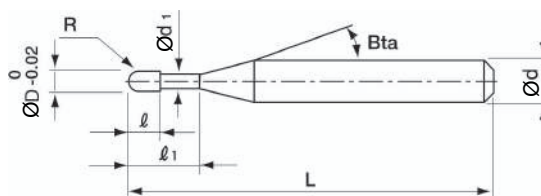

The shank taper angle shown is not an exact value.

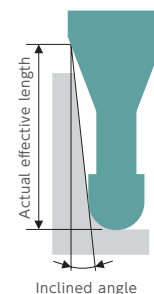

Total 31 models

Unit (mm)

Model Number	Radius of Ball Nose R	Effective Length $l_1$	Length of Cut $l$	Neck Diameter $\phi d_1$	Shank Taper Angle Bta	Overall Length L	Shank Diameter $\phi d$	Series	Effective Length by Inclined Angles				
									30°	1°	1°30'	2°	3°
UDCLBH 2004-0050	R0.2	0.5	0.28	0.375	16°	50	4	UDCLBH	0.51	0.52	0.54	0.55	0.58
UDCLBH 2004-0100		1							1.03	1.06	1.09	1.12	1.19
UDCLBH 2006-0100	R0.3	1	0.42	0.575	16°	50	4	UDCLBH	1.03	1.05	1.08	1.10	1.17
UDCLBH 2006-0150		1.5							1.54	1.58	1.63	1.67	1.78
UDCLBH 2006-0200		2							2.06	2.12	2.18	2.24	2.39
UDCLBH 2006-0300		3							3.09	3.18	3.28	3.38	3.61
UDCLBH 2007-0100	R0.35	1	0.49	0.675	16°	50	4	UDCLBH	1.02	1.05	1.07	1.10	1.16
UDCLBH 2008-0200	R0.4	2	0.56	0.775	16°	50	4	UDCLBH	2.05	2.11	2.17	2.23	2.37
UDCLBH 2008-0300		3							3.09	3.17	3.27	3.37	3.59
UDCLBH 2008-0400		4							4.12	4.24	4.37	4.51	4.82
UDCLBH 2010-0150	R0.5	1.5	0.7	0.975	16°	50	4	UDCLBH	1.54	1.57	1.61	1.65	1.73
UDCLBH 2010-0200		2							2.05	2.10	2.16	2.22	2.35
UDCLBH 2010-0250		2.5							2.57	2.63	2.71	2.78	2.96
UDCLBH 2010-0300		3							3.08	3.17	3.26	3.35	3.57
UDCLBH 2010-0400		4							4.11	4.23	4.36	4.49	4.79
UDCLBH 2010-0500	5	5.15	5.30	5.46	5.63	6.02							

2 Flute High-speed Long Neck Ball End Mills for Cemented Carbide and Hard Brittle Materials

Model Number	Radius of Ball Nose R	Effective Length $\ell_1$	Length of Cut $\ell$	Neck Diameter $\phi d_1$	Shank Taper Angle $\beta$	Overall Length L	Shank Diameter $\phi d$	Series	Effective Length by Inclined Angles				
									30°	1°	1°30'	2°	3°
UDCLBH 2015-0200	R0.75	2	1.05	1.455	16°	50	4	UDCLBH	2.08	2.12	2.17	2.22	2.33
UDCLBH 2015-0400		4							4.14	4.25	4.37	4.50	4.78
UDCLBH 2015-0600		6							6.21	6.38	6.57	6.78	7.23
UDCLBH 2020-0300	R1	3	1.4	1.915	16°	50	4	UDCLBH	3.18	3.25	3.32	3.41	3.59
UDCLBH 2020-0400		4							4.21	4.31	4.42	4.54	4.81
UDCLBH 2020-0600		6							6.27	6.44	6.62	6.82	7.26
UDCLBH 2020-0800		8							8.33	8.57	8.83	9.10	9.71
UDCLBH 2020-1000		10							10.39	10.70	11.03	11.38	12.15
※ UDCLBH 2030-0600	R1.5	6	2.1	2.9	16°	60	6	UDCLBH	6.28	6.44	6.60	6.78	7.18
※ UDCLBH 2030-0800		8							8.34	8.57	8.80	9.06	9.63
※ UDCLBH 2040-0800	R2	8	2.8	3.9	16°	60	6	UDCLBH	8.33	8.53	8.76	8.99	9.52
※ UDCLBH 2040-1000		10							10.39	10.66	10.96	11.27	11.97
※ UDCLBH 2050-1000	R2.5	10	3.5	4.8	16°	60	6	UDCLBH	10.55	10.82	11.10	11.40	12.07
※ UDCLBH 2060-1000	R3	10	4.2	5.7	—	60	6	UDCLBH	No Interference	No Interference	No Interference	No Interference	No Interference
※ UDCLBH 2060-1500		15							No Interference	No Interference	No Interference	No Interference	No Interference

※ Additional model

# UDCLBH Milling Conditions

WORK MATERIAL			CEMENTED CARBIDE (≥87 HRA)					CEMENTED CARBIDE (<87 HRA)					HARD BRITTLE MATERIALS				
Model Number	Radius of Ball Nose (mm)	Effective Length (mm)	Spindle Speed (min <sup>-1</sup> )	Feed Rate (mm/min)	*Feed Rate2 (mm/min)	a <sub>p</sub> Axial Depth (mm)	a <sub>e</sub> Radial Depth (mm)	Spindle Speed (min <sup>-1</sup> )	Feed Rate (mm/min)	*Feed Rate2 (mm/min)	a <sub>p</sub> Axial Depth (mm)	a <sub>e</sub> Radial Depth (mm)	Spindle Speed (min <sup>-1</sup> )	Feed Rate (mm/min)	*Feed Rate2 (mm/min)	a <sub>p</sub> Axial Depth (mm)	a <sub>e</sub> Radial Depth (mm)
2004-0050	R0.2	0.5	30,000	450	45	0.02	0.08	30,000	600	60	0.08	0.02	30,000	150	15	0.02	0.08
2004-0100		1	30,000	300	30	0.015	0.07	30,000	300	30	0.07	0.015	30,000	100	10	0.015	0.07
2006-0100	R0.3	1	30,000	600	200	0.03	0.14	30,000	450	150	0.17	0.03	30,000	200	20	0.03	0.14
2006-0150		1.5	30,000	600	200	0.03	0.14	30,000	300	100	0.14	0.025	30,000	200	20	0.03	0.14
2006-0200		2	30,000	300	100	0.022	0.11	30,000	220	70	0.11	0.02	30,000	150	15	0.02	0.11
2006-0300		3	30,000	75	10	0.01	0.08	30,000	75	10	0.08	0.01	30,000	75	10	0.01	0.08
2007-0100	R0.35	1	30,000	690	230	0.035	0.17	30,000	525	260	0.18	0.035	30,000	225	23	0.035	0.17
2008-0200	R0.4	2	30,000	750	250	0.04	0.19	27,000	480	240	0.19	0.04	30,000	250	25	0.04	0.19
2008-0300		3	30,000	350	100	0.037	0.17	25,500	300	100	0.17	0.035	30,000	230	23	0.037	0.17
2008-0400		4	26,000	210	70	0.035	0.16	24,000	210	21	0.16	0.035	30,000	210	21	0.035	0.16
2010-0150	R0.5	1.5	30,000	900	300	0.05	0.22	25,000	650	325	0.2	0.05	30,000	300	30	0.05	0.25
2010-0200		2	30,000	900	300	0.05	0.22	24,000	580	290	0.2	0.05	30,000	300	30	0.05	0.25
2010-0250		2.5	30,000	800	300	0.05	0.22	23,500	520	260	0.2	0.05	30,000	300	30	0.05	0.25
2010-0300		3	30,000	600	200	0.05	0.22	23,000	450	220	0.2	0.05	30,000	300	30	0.05	0.25
2010-0400		4	30,000	400	100	0.05	0.22	21,000	320	160	0.2	0.05	30,000	300	30	0.05	0.25
2010-0500		5	27,000	270	100	0.045	0.2	20,000	250	125	0.2	0.05	27,000	270	30	0.045	0.2
2015-0200	R0.75	2	30,000	1,200	400	0.075	0.27	19,000	750	375	0.23	0.07	24,000	400	45	0.075	0.27
2015-0400		4	30,000	900	250	0.075	0.27	18,000	580	290	0.23	0.07	24,000	350	40	0.075	0.27
2015-0600		6	25,000	500	100	0.075	0.27	17,000	400	200	0.23	0.07	24,000	320	36	0.075	0.27
2020-0300	R1	3	30,000	1,500	500	0.1	0.3	16,500	800	400	0.25	0.1	18,000	600	200	0.1	0.3
2020-0400		4	30,000	1,500	500	0.1	0.3	15,750	750	375	0.25	0.1	18,000	500	160	0.1	0.3
2020-0600		6	20,000	850	280	0.1	0.3	15,000	620	310	0.25	0.1	18,000	400	130	0.1	0.3
2020-0800		8	13,000	400	130	0.1	0.3	14,000	520	260	0.25	0.1	18,000	350	120	0.1	0.3
2020-1000		10	10,000	200	60	0.1	0.3	13,000	420	210	0.25	0.1	18,000	300	100	0.1	0.3
2030-0600	R1.5	6	24,000	1,200	400	0.1	0.3	9,000	280	140	0.38	0.15	20,000	200	100	0.15	0.3
2030-0800		8	24,000	1,200	400	0.1	0.3	9,000	280	140	0.38	0.15	20,000	200	100	0.15	0.3
2040-0800	R2	8	18,000	900	300	0.125	0.325	7,200	280	140	0.5	0.2	18,000	180	90	0.175	0.32
2040-1000		10	18,000	900	300	0.125	0.325	7,200	280	140	0.5	0.2	18,000	180	90	0.175	0.32
2050-1000	R2.5	10	12,000	600	200	0.175	0.37	6,000	330	170	0.6	0.25	16,000	160	80	0.252	0.31
2060-1000	R3	10	9,000	500	166	0.2	0.4	5,500	280	140	0.65	0.28	15,000	150	75	0.3	0.3
2060-1500		15	9,000	500	166	0.2	0.4	5,500	280	140	0.65	0.28	15,000	150	75	0.3	0.3

\*Feed Rate2: Feed rate of approach and \*connection moves.

\*Changing from one engagement point to the next.

Equivalent to UDCLBF conditions

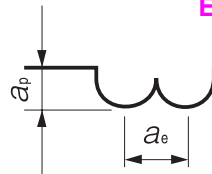

# UDCLBH R1 × EL4

Connector shaped milling

Cemented Carbide  
VM-40 (90 HRA)

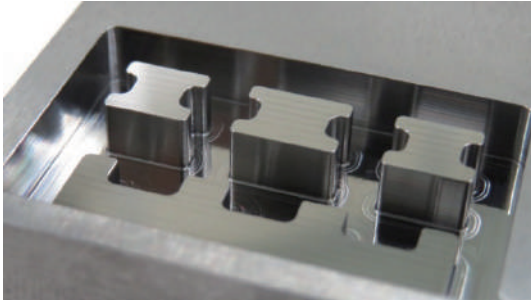

Model Size: 26 x 16 x 4mm

Pocket Volume: 1,304mm<sup>3</sup>

Coolant: Air Blow

## R1 × EL4

Effective Length Comparison of milling efficiency

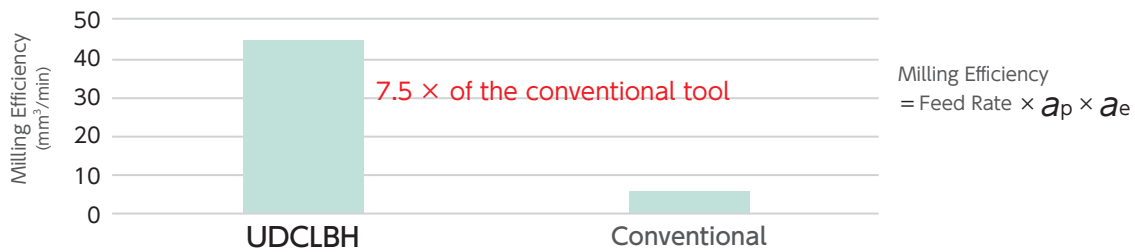

## T1

Tool after milling

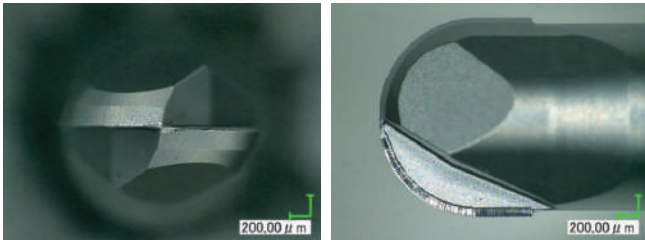

Less tool damage even with highly efficient milling!

No	Process	Tool no	Tool	Spindle Speed (min <sup>-1</sup> )	Feed Rate (mm/min)	$a_p$ Axial Depth (mm)	$a_e$ Radial Depth (mm)	Allowance (mm)	Cycle Time (h:m:s)
1	Roughing	T1	UDCLBH 2020-0400 (R1 × EL4)	30,000	1,500	0.1	0.3	0.03	0:24:52
2	Corner Removal 1	T2	UDCLBH 2010-0400 (R0.5 × EL4)	30,000	400	0.05	0.11	0.03	0:33:12
3	Corner Removal 2	T3	UDCLRSF 2010-005040 (Ø1 × CR0.05 × EL4)	30,000	190	0.02	0.6	0.03	0:15:23
4	Top surface/ Semi-finishing			30,000	190	—	0.6	0.01	0:03:11
5	Wall surface / Semi-finishing	T2	UDCLBH 2010-0400 (R0.5 × EL4)	30,000	400	0.05	0.22	0.01	0:38:22
6	Corner & Bottom surface/ Semi-finishing	T3	UDCLRSF 2010-005040 (Ø1 × CR0.05 × EL4)	30,000	190	0.006	0.3	0.01	0:48:30
7	Top surface / Finishing	T4	UDCLRSF 2010-005040 (Ø1 × CR0.05 × EL4)	30,000	190	—	0.6	0	0:03:15
8	Wall surface / Finishing			30,000	375	0.25	—	0	0:08:17
9	Corner & Bottom surface/ Finishing			30,000	190	0.014	0.3	0	0:46:09

Total 4pcs are used.

Total 3:41:11

# UDCLBF



2 Flute High-grade Long Neck Ball End Mills for Cemented Carbide and Hard Brittle Materials

R0.1~R3



Material Applications (★ Highly Recommended ● Recommended ○ Suggested)

Work Material																	
CARBON STEELS S45C S55C	ALLOY STEELS SK / SCM SUS	PREHARDENED STEELS NAK HPM	HARDENED STEELS					CAST IRON	ALUMINUM ALLOYS	GRAPHITE	COPPER	PLASTICS	ガラス入り樹脂 FILLED PLASTICS	TITANIUM ALLOYS	HEAT RESISTANT ALLOYS	CEMENTED CARBIDE	HARD BRITTLE (NON-METALLIC) MATERIALS
			~ 50 HRC	~ 55 HRC	~ 60 HRC	~ 65 HRC	~ 70 HRC										
												○			★	●	

※Hard Brittle (Non-Metallic) Materials: Ceramics (Alumina, Zirconia, etc.), Glasses and etc.



For excellent surface quality

Label Sample



#001 ØD0.389 R0.000/-0.004

Diameter and Ball Radius accuracy measurements are printed on the label to support High Precision milling.

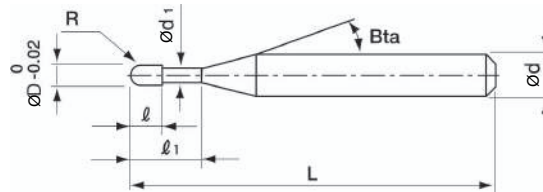

The shank taper angle shown is not an exact value.

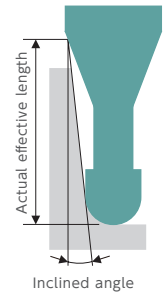

Total 61 models

Unit (mm)

Model Number	Radius of Ball Nose R	Effective Length $l_1$	Length of Cut $l$	Neck Diameter $\phi d_1$	Shank Taper Angle Bta	Overall Length L	Shank Diameter $\phi d$	Series	Effective Length by Inclined Angles				
									30°	1°	1°30'	2°	3°
UDCLBF 2002-0030	R0.1	0.3	0.14	0.18	16°	50	4	UDCLBF	0.30	0.31	0.32	0.32	0.34
UDCLBF 2002-0050		0.5							0.51	0.52	0.54	0.55	0.59
UDCLBF 2002-0075		0.75							0.77	0.79	0.81	0.84	0.89
UDCLBF 2002-0100		1							1.02	1.05	1.09	1.12	1.20
UDCLBF 2003-0050	R0.15	0.5	0.21	0.28	16°	50	4	UDCLBF	0.51	0.52	0.53	0.55	0.58
UDCLBF 2003-0075		0.75							0.76	0.78	0.81	0.83	0.88
UDCLBF 2003-0100		1							1.02	1.05	1.08	1.11	1.19
UDCLBF 2004-0050	R0.2	0.5	0.28	0.36	16°	50	4	UDCLBF	0.54	0.55	0.56	0.58	0.61
UDCLBF 2004-0100		1							1.06	1.08	1.12	1.15	1.22
UDCLBF 2004-0150		1.5							1.57	1.62	1.67	1.72	1.83
UDCLBF 2004-0200		2							2.09	2.15	2.22	2.29	2.44
UDCLBF 2004-0250		2.5							2.60	2.68	2.77	2.86	3.06
UDCLBF 2006-0100	R0.3	1	0.42	0.56	16°	50	4	UDCLBF	1.05	1.08	1.11	1.13	1.20
UDCLBF 2006-0150		1.5							1.57	1.61	1.66	1.70	1.81
UDCLBF 2006-0200		2							2.08	2.14	2.21	2.27	2.42
UDCLBF 2006-0300		3							3.12	3.21	3.31	3.41	3.65
UDCLBF 2006-0400		4							4.15	4.27	4.41	4.55	4.87
UDCLBF 2006-0500		5							5.18	5.34	5.51	5.69	6.09
UDCLBF 2006-0600		6							6.21	6.40	6.61	6.83	7.32



2 Flute High-grade Long Neck Ball End Mills for Cemented Carbide and Hard Brittle Materials

Model Number	Radius of Ball Nose R	Effective Length $\ell_1$	Length of Cut $\ell$	Neck Diameter $\varnothing d_1$	Shank Taper Angle $\beta_{ta}$	Overall Length L	Shank Diameter $\varnothing d$	Series	Effective Length by Inclined Angles				
									30°	1°	1°30'	2°	3°
UDCLBF 2008-0200	R0.4	2	0.56	0.76	16°	50	4	UDCLBF	2.08	2.14	2.20	2.26	2.40
UDCLBF 2008-0300		3				50	4	UDCLBF	3.11	3.20	3.30	3.40	3.62
UDCLBF 2008-0400		4				50	4	UDCLBF	4.14	4.27	4.40	4.54	4.85
UDCLBF 2008-0500		5				50	4	UDCLBF	5.18	5.33	5.50	5.67	6.07
UDCLBF 2008-0600		6				50	4	UDCLBF	6.21	6.40	6.60	6.81	7.29
UDCLBF 2008-0800		8				50	4	UDCLBF	8.27	8.53	8.80	9.09	9.74
UDCLBF 2010-0150	R0.5	1.5	0.7	0.96	16°	50	4	UDCLBF	1.56	1.60	1.64	1.68	1.77
UDCLBF 2010-0200		2				50	4	UDCLBF	2.08	2.13	2.19	2.25	2.38
UDCLBF 2010-0250		2.5				50	4	UDCLBF	2.59	2.66	2.74	2.81	2.99
UDCLBF 2010-0300		3				50	4	UDCLBF	3.11	3.20	3.29	3.38	3.60
UDCLBF 2010-0400		4				50	4	UDCLBF	4.14	4.26	4.39	4.52	4.83
UDCLBF 2010-0600		6				50	4	UDCLBF	6.20	6.39	6.59	6.80	7.27
UDCLBF 2010-0800		8				50	4	UDCLBF	8.27	8.52	8.79	9.08	9.72
UDCLBF 2010-1000		10				50	4	UDCLBF	10.33	10.65	10.99	11.35	12.17
UDCLBF 2015-0200	R0.75	2	1.05	1.44	16°	50	4	UDCLBF	2.11	2.15	2.20	2.25	2.37
UDCLBF 2015-0400		4				50	4	UDCLBF	4.17	4.28	4.40	4.53	4.81
UDCLBF 2015-0600		6				50	4	UDCLBF	6.23	6.41	6.60	6.81	7.26
UDCLBF 2015-0800		8				50	4	UDCLBF	8.29	8.54	8.80	9.08	9.71
UDCLBF 2015-1000		10				50	4	UDCLBF	10.36	10.67	11.00	11.36	12.16
UDCLBF 2015-1200		12				50	4	UDCLBF	12.42	12.80	13.20	13.64	14.60
UDCLBF 2020-0300	R1	3	1.4	1.9	16°	50	4	UDCLBF	3.20	3.27	3.35	3.43	3.62
UDCLBF 2020-0400		4				50	4	UDCLBF	4.23	4.34	4.45	4.57	4.84
UDCLBF 2020-0600		6				50	4	UDCLBF	6.30	6.47	6.65	6.85	7.29
UDCLBF 2020-0800		8				50	4	UDCLBF	8.36	8.60	8.85	9.13	9.74
UDCLBF 2020-1000		10				50	4	UDCLBF	10.42	10.73	11.06	11.41	12.19
UDCLBF 2020-1200		12				50	4	UDCLBF	12.48	12.86	13.26	13.68	14.63
UDCLBF 2020-1400		14				50	4	UDCLBF	14.55	14.99	15.46	15.96	17.08
UDCLBF 2020-1600		16				50	4	UDCLBF	16.61	17.12	17.66	18.24	19.53
UDCLBF 2020-1800		18				60	4	UDCLBF	18.67	19.25	19.86	20.52	No Interference
UDCLBF 2020-2000		20				60	4	UDCLBF	20.74	21.38	22.06	22.79	No Interference
UDCLBF 2030-0600	R1.5	6	2.1	2.9	16°	60	6	UDCLBF	6.28	6.44	6.60	6.78	7.18
UDCLBF 2030-0800		8				60	6	UDCLBF	8.34	8.57	8.80	9.06	9.63
UDCLBF 2030-1000		10				60	6	UDCLBF	10.41	10.70	11.01	11.34	12.08
UDCLBF 2030-1200		12				60	6	UDCLBF	12.47	12.83	13.21	13.61	14.52
UDCLBF 2030-1400		14				60	6	UDCLBF	14.53	14.96	15.41	15.89	16.97
UDCLBF 2040-0800	R2	8	2.8	3.9	16°	60	6	UDCLBF	8.33	8.53	8.76	8.99	9.52
UDCLBF 2040-1000		10				60	6	UDCLBF	10.39	10.66	10.96	11.27	11.97
UDCLBF 2040-1500		15				60	6	UDCLBF	15.55	15.99	16.46	16.96	18.09
UDCLBF 2050-1000	R2.5	10	3.5	4.8	16°	60	6	UDCLBF	10.55	10.82	11.10	11.40	12.07
UDCLBF 2050-1500		15				60	6	UDCLBF	15.71	16.14	16.60	17.09	No Interference
UDCLBF 2060-1000	R3	10	4.2	5.7	—	60	6	UDCLBF	No Interference	No Interference	No Interference	No Interference	No Interference
UDCLBF 2060-1500		15				60	6	UDCLBF	No Interference	No Interference	No Interference	No Interference	No Interference

WORK MATERIAL			CEMENTED CARBIDE ( $\geq 87$ HRA) / HARD BRITTLE MATERIALS					CEMENTED CARBIDE ( $< 87$ HRA)				
Model Number	Radius of Ball Nose (mm)	Effective Length (mm)	Spindle Speed ( $\text{min}^{-1}$ )	Feed Rate (mm/min)	*Feed Rate2 (mm/min)	$a_p$ Axial Depth (mm)	$a_e$ Radial Depth (mm)	Spindle Speed ( $\text{min}^{-1}$ )	Feed Rate (mm/min)	*Feed Rate2 (mm/min)	$a_p$ Axial Depth (mm)	$a_e$ Radial Depth (mm)
2002-0030	R0.1	0.3	30,000	100	10	0.01	0.01	30,000	100	10	0.01	0.01
2002-0050		0.5	30,000	30	10	0.005	0.008	30,000	30	10	0.005	0.008
2002-0075		0.75	30,000	30	10	0.005	0.006	30,000	30	10	0.005	0.006
2002-0100		1	30,000	25	10	0.005	0.005	30,000	25	10	0.005	0.005
2003-0050	R0.15	0.5	30,000	100	10	0.01	0.03	30,000	100	10	0.01	0.03
2003-0075		0.75	30,000	80	10	0.01	0.02	30,000	80	10	0.01	0.02
2003-0100		1	30,000	60	10	0.01	0.02	30,000	60	10	0.01	0.02
2004-0050	R0.2	0.5	30,000	150	15	0.02	0.08	30,000	150	15	0.02	0.08
2004-0100		1	30,000	100	10	0.015	0.07	30,000	100	10	0.015	0.07
2004-0150		1.5	30,000	60	10	0.01	0.06	30,000	60	10	0.01	0.06
2004-0200		2	30,000	30	10	0.008	0.05	30,000	30	10	0.008	0.05
2004-0250		2.5	30,000	15	10	0.006	0.03	30,000	15	10	0.006	0.03
2006-0100	R0.3	1	30,000	200	20	0.03	0.14	30,000	200	20	0.03	0.14
2006-0150		1.5	30,000	200	20	0.03	0.14	30,000	200	20	0.03	0.14
2006-0200		2	30,000	150	15	0.022	0.11	30,000	150	15	0.022	0.11
2006-0300		3	30,000	75	10	0.01	0.08	30,000	75	10	0.01	0.08
2006-0400		4	30,000	75	10	0.01	0.08	30,000	75	10	0.01	0.08
2006-0500		5	30,000	75	10	0.01	0.06	30,000	75	10	0.01	0.06
2006-0600	6	30,000	75	10	0.01	0.03	30,000	75	10	0.01	0.03	
2008-0200	R0.4	2	30,000	250	25	0.04	0.19	30,000	250	25	0.04	0.19
2008-0300		3	30,000	230	23	0.037	0.17	30,000	230	23	0.037	0.17
2008-0400		4	30,000	210	21	0.035	0.16	30,000	210	21	0.035	0.16
2008-0500		5	25,000	170	20	0.03	0.12	25,000	170	20	0.03	0.12
2008-0600		6	20,000	130	20	0.025	0.08	20,000	130	20	0.025	0.08
2008-0800	8	15,000	100	20	0.015	0.03	15,000	100	20	0.015	0.03	
2010-0150	R0.5	1.5	30,000	300	30	0.05	0.25	30,000	300	150	0.35	0.075
2010-0200		2	30,000	300	30	0.05	0.25	30,000	300	150	0.35	0.075
2010-0250		2.5	30,000	300	30	0.05	0.25	30,000	300	150	0.35	0.075
2010-0300		3	30,000	300	30	0.05	0.25	25,000	250	125	0.35	0.075
2010-0400		4	30,000	300	30	0.05	0.25	25,000	250	125	0.2	0.1
2010-0600		6	25,000	250	25	0.04	0.15	25,000	250	125	0.1	0.1
2010-0800		8	20,000	200	25	0.025	0.07	20,000	200	100	0.03	0.08
2010-1000	10	10,000	100	20	0.018	0.03	20,000	200	100	0.02	0.04	
2015-0200	R0.75	2	25,000	250	45	0.075	0.27	18,000	180	90	0.52	0.12
2015-0400		4	25,000	250	45	0.075	0.27	18,000	180	90	0.52	0.12
2015-0600		6	25,000	250	45	0.075	0.27	18,000	180	90	0.4	0.12
2015-0800		8	20,000	160	30	0.075	0.27	18,000	180	90	0.2	0.2
2015-1000		10	20,000	130	30	0.05	0.15	18,000	180	90	0.075	0.25
2015-1200	12	16,000	100	30	0.03	0.08	13,500	135	70	0.05	0.16	

WORK MATERIAL			CEMENTED CARBIDE (≥87 HRA) / HARD BRITTLE MATERIALS					CEMENTED CARBIDE (<87 HRA)				
Model Number	Radius of Ball Nose (mm)	Effective Length (mm)	Spindle Speed (min <sup>-1</sup> )	Feed Rate (mm/min)	*Feed Rate2 (mm/min)	$a_p$ Axial Depth (mm)	$a_e$ Radial Depth (mm)	Spindle Speed (min <sup>-1</sup> )	Feed Rate (mm/min)	*Feed Rate2 (mm/min)	$a_p$ Axial Depth (mm)	$a_e$ Radial Depth (mm)
2020-0300	R1	3	20,000	200	60	0.1	0.3	12,500	125	60	0.7	0.15
2020-0400		4	20,000	200	60	0.1	0.3	12,500	125	60	0.7	0.15
2020-0600		6	20,000	200	60	0.1	0.3	12,500	125	60	0.7	0.15
2020-0800		8	20,000	200	60	0.1	0.3	12,500	125	60	0.4	0.2
2020-1000		10	20,000	200	60	0.1	0.3	12,500	125	60	0.25	0.25
2020-1200		12	20,000	200	60	0.09	0.25	12,500	125	60	0.1	0.3
2020-1400		14	20,000	200	60	0.07	0.15	12,500	125	60	0.1	0.3
2020-1600		16	13,000	130	36	0.04	0.08	12,500	125	60	0.1	0.3
2020-1800		18	10,000	100	30	0.025	0.05	10,000	100	50	0.04	0.1
2020-2000		20	10,000	100	30	0.02	0.035	10,000	100	50	0.02	0.07
2030-0600	R1.5	6	20,000	200	100	0.15	0.3	9,000	280	140	0.38	0.15
2030-0800		8	20,000	200	100	0.15	0.3	9,000	280	140	0.38	0.15
2030-1000		10	20,000	200	100	0.15	0.3	9,000	280	140	0.38	0.15
2030-1200		12	20,000	200	100	0.15	0.3	9,000	280	140	0.38	0.15
2030-1400		14	20,000	200	100	0.15	0.3	9,000	280	140	0.38	0.15
2040-0800	R2	8	18,000	180	90	0.175	0.32	7,200	280	140	0.5	0.2
2040-1000		10	18,000	180	90	0.175	0.32	7,200	280	140	0.5	0.2
2040-1500		15	18,000	180	90	0.175	0.32	7,200	280	140	0.5	0.2
2050-1000	R2.5	10	16,000	160	80	0.225	0.31	6,000	330	170	0.6	0.25
2050-1500		15	16,000	160	80	0.225	0.31	6,000	330	170	0.6	0.25
2060-1000	R3	10	15,000	150	75	0.3	0.3	5,500	280	140	0.65	0.28
2060-1500		15	15,000	150	75	0.3	0.3	5,500	280	140	0.65	0.28

\*Feed Rate2: Feed rate of approach and \*connection moves.

\*Changing from one engagement point to the next.

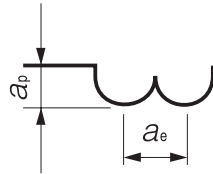

# UDCLB



2 Flute Long Neck Ball End Mills for Cemented Carbide and Hard Brittle Materials

R0.1 ~ R3



Material Applications (★ Highly Recommended ● Recommended ○ Suggested)

Work Material																	
CARBON STEELS S45C S55C	ALLOY STEELS SK / SCM SUS	PREHARDENED STEELS NAK HPM	HARDENED STEELS					CAST IRON	ALUMINUM ALLOYS	GRAPHITE	COPPER	PLASTICS	GLASS FILLED PLASTICS	TITANIUM ALLOYS	HEAT RESISTANT ALLOYS	CEMENTED CARBIDE	HARD BRITTLE (NON-METALLIC) MATERIALS
			~ 50 HRC	~ 55 HRC	~ 60 HRC	~ 65 HRC	~ 70 HRC										
												○ ※1			★	● ※2	

- ※ 1 DCB / DCLB series are highly recommended for Glass Filled Plastic milling.
- ※ 2 Hard Brittle (Non-Metallic) Materials: Ceramics (Alumina, Zirconia, etc.), Glasses and etc.

## Entry Series

For low-cost milling

Label Sample



#001 <D1.985 R+0.001/-0.002

Diameter and Ball Radius accuracy measurements are printed on the label to support High Precision milling.

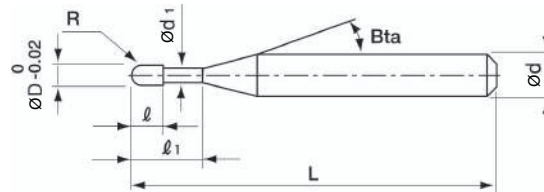

The shank taper angle shown is not an exact value.

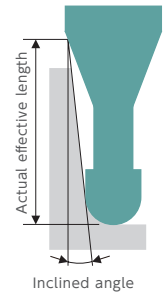

Total 37 models

Unit (mm)

Model Number	Radius of Ball Nose R	Effective Length ℓ <sub>1</sub>	Length of Cut ℓ	Neck Diameter ØD <sub>1</sub>	Shank Taper Angle Bta	Overall Length L	Shank Diameter Ød	Series	Effective Length by Inclined Angles				
									30°	1°	1°30'	2°	3°
UDCLB 2002-0030	R0.1	0.3	0.14	0.18	16°	50	4	UDCLB	0.30	0.31	0.32	0.32	0.34
UDCLB 2002-0050		0.5				50	4	UDCLB	0.51	0.52	0.54	0.55	0.59
UDCLB 2002-0075		0.75				50	4	UDCLB	0.77	0.79	0.81	0.84	0.89
UDCLB 2002-0100		1				50	4	UDCLB	1.02	1.05	1.09	1.12	1.20
UDCLB 2004-0050	R0.2	0.5	0.28	0.36	16°	50	4	UDCLB	0.54	0.55	0.56	0.58	0.61
UDCLB 2004-0100		1				50	4	UDCLB	1.06	1.08	1.12	1.15	1.22
UDCLB 2004-0150		1.5				50	4	UDCLB	1.57	1.62	1.67	1.72	1.83
UDCLB 2004-0200		2				50	4	UDCLB	2.09	2.15	2.22	2.29	2.44
UDCLB 2006-0100	R0.3	1	0.42	0.56	16°	50	4	UDCLB	1.05	1.08	1.11	1.13	1.20
UDCLB 2006-0150		1.5				50	4	UDCLB	1.57	1.61	1.66	1.70	1.81
UDCLB 2006-0200		2				50	4	UDCLB	2.08	2.14	2.21	2.27	2.42
UDCLB 2006-0300		3				50	4	UDCLB	3.12	3.21	3.31	3.41	3.65
UDCLB 2008-0200	R0.4	2	0.56	0.76	16°	50	4	UDCLB	2.08	2.14	2.20	2.26	2.40
UDCLB 2008-0300		3				50	4	UDCLB	3.11	3.20	3.30	3.40	3.62
UDCLB 2008-0400		4				50	4	UDCLB	4.14	4.27	4.40	4.54	4.85

2 Flute Long Neck Ball End Mills for Cemented Carbide and Hard Brittle Materials

Model Number	Radius of Ball Nose R	Effective Length $\ell_1$	Length of Cut $\ell$	Neck Diameter $\phi d_1$	Shank Taper Angle Bta	Overall Length L	Shank Diameter $\phi d$	Series	Effective Length by Inclined Angles				
									30°	1°	1°30'	2°	3°
UDCLB 2010-0200	R0.5	2	0.7	0.96	16°	50	4	UDCLB	2.08	2.13	2.19	2.25	2.38
UDCLB 2010-0250		2.5							2.59	2.66	2.74	2.81	2.99
UDCLB 2010-0300		3							3.11	3.20	3.29	3.38	3.60
UDCLB 2010-0400		4							4.14	4.26	4.39	4.52	4.83
UDCLB 2010-0500		5							5.17	5.32	5.49	5.66	6.05
UDCLB 2020-0300	R1	3	1.4	1.9	16°	50	4	UDCLB	3.20	3.27	3.35	3.43	3.62
UDCLB 2020-0400		4							4.23	4.34	4.45	4.57	4.84
UDCLB 2020-0600		6							6.30	6.47	6.65	6.85	7.29
UDCLB 2020-0800		8							8.36	8.60	8.85	9.13	9.74
UDCLB 2020-1000		10							10.42	10.73	11.06	11.41	12.19
UDCLB 2030-0600	R1.5	6	2.1	2.9	16°	60	6	UDCLB	6.28	6.44	6.60	6.78	7.18
UDCLB 2030-0800		8							8.34	8.57	8.80	9.06	9.63
UDCLB 2030-1000		10							10.41	10.70	11.01	11.34	12.08
UDCLB 2030-1200		12							12.47	12.83	13.21	13.61	14.52
UDCLB 2030-1400		14							14.53	14.96	15.41	15.89	16.97
UDCLB 2040-0800	R2	8	2.8	3.9	16°	60	6	UDCLB	8.33	8.53	8.76	8.99	9.52
UDCLB 2040-1000		10							10.39	10.66	10.96	11.27	11.97
UDCLB 2040-1500		15							15.55	15.99	16.46	16.96	18.09
UDCLB 2050-1000	R2.5	10	3.5	4.8	16°	60	6	UDCLB	10.55	10.82	11.10	11.40	12.07
UDCLB 2050-1500		15							15.71	16.14	16.60	17.09	No Interference
UDCLB 2060-1000	R3	10	4.2	5.7	—	60	6	UDCLB	No Interference	No Interference	No Interference	No Interference	No Interference
UDCLB 2060-1500		15							No Interference	No Interference	No Interference	No Interference	No Interference

WORK MATERIAL			CEMENTED CARBIDE (≥ 87 HRA)					CEMENTED CARBIDE (< 87 HRA)					HARD BRITTLE MATERIALS				
Model Number	Radius of Ball Nose (mm)	Effective Length (mm)	Spindle Speed (min <sup>-1</sup> )	Feed Rate (mm/min)	*Feed Rate2 (mm/min)	a <sub>p</sub> Axial Depth (mm)	a <sub>e</sub> Radial Depth (mm)	Spindle Speed (min <sup>-1</sup> )	Feed Rate (mm/min)	*Feed Rate2 (mm/min)	a <sub>p</sub> Axial Depth (mm)	a <sub>e</sub> Radial Depth (mm)	Spindle Speed (min <sup>-1</sup> )	Feed Rate (mm/min)	*Feed Rate2 (mm/min)	a <sub>p</sub> Axial Depth (mm)	a <sub>e</sub> Radial Depth (mm)
2002-0030	R0.1	0.3	30,000	100	10	0.01	0.01	30,000	100	10	0.01	0.01	30,000	100	10	0.01	0.01
2002-0050		0.5	30,000	30	10	0.005	0.008	30,000	30	10	0.005	0.008	30,000	30	10	0.005	0.008
2002-0075		0.75	30,000	30	10	0.005	0.006	30,000	30	10	0.005	0.006	30,000	30	10	0.005	0.006
2002-0100		1	30,000	25	10	0.005	0.005	30,000	25	10	0.005	0.005	30,000	25	10	0.005	0.005
2004-0050	R0.2	0.5	30,000	150	15	0.02	0.08	30,000	150	15	0.02	0.08	30,000	150	15	0.02	0.08
2004-0100		1	30,000	100	10	0.015	0.07	30,000	100	10	0.015	0.07	30,000	100	10	0.015	0.07
2004-0150		1.5	30,000	60	10	0.01	0.06	30,000	60	10	0.01	0.06	30,000	60	10	0.01	0.06
2004-0200		2	30,000	30	10	0.008	0.05	30,000	30	10	0.008	0.05	30,000	30	10	0.008	0.05
2006-0100	R0.3	1	30,000	200	20	0.03	0.14	30,000	200	20	0.03	0.14	30,000	200	20	0.03	0.14
2006-0150		1.5	30,000	200	20	0.03	0.14	30,000	200	20	0.03	0.14	30,000	200	20	0.03	0.14
2006-0200		2	30,000	150	15	0.022	0.11	30,000	150	15	0.022	0.11	30,000	150	15	0.022	0.11
2006-0300		3	30,000	75	10	0.01	0.08	30,000	75	10	0.01	0.08	30,000	75	10	0.01	0.08
2008-0200	R0.4	2	30,000	250	25	0.04	0.19	30,000	250	25	0.04	0.19	30,000	250	25	0.04	0.19
2008-0300		3	30,000	230	23	0.037	0.17	30,000	230	23	0.037	0.17	30,000	230	23	0.037	0.17
2008-0400		4	30,000	210	21	0.035	0.16	30,000	210	21	0.035	0.16	30,000	210	21	0.035	0.16
2010-0200	R0.5	2	30,000	300	30	0.05	0.25	20,000	400	200	0.35	0.075	30,000	300	30	0.05	0.25
2010-0250		2.5	30,000	300	30	0.05	0.25	20,000	400	200	0.35	0.075	30,000	300	30	0.05	0.25
2010-0300		3	30,000	300	30	0.05	0.25	20,000	400	200	0.35	0.075	30,000	300	30	0.05	0.25
2010-0400		4	30,000	300	30	0.05	0.25	20,000	400	200	0.3	0.07	30,000	300	30	0.05	0.25
2010-0500		5	30,000	300	30	0.05	0.25	20,000	400	200	0.3	0.07	30,000	300	30	0.05	0.25
2020-0300	R1	3	30,000	300	100	0.1	0.3	16,500	420	210	0.25	0.1	24,000	240	100	0.1	0.3
2020-0400		4	30,000	300	100	0.1	0.3	16,500	420	210	0.25	0.1	24,000	240	100	0.1	0.3
2020-0600		6	30,000	300	100	0.1	0.3	16,500	420	210	0.25	0.1	24,000	240	100	0.1	0.3
2020-0800		8	30,000	300	100	0.1	0.3	16,500	420	210	0.25	0.1	24,000	240	100	0.1	0.3
2020-1000		10	30,000	300	100	0.1	0.3	16,500	420	210	0.25	0.1	24,000	240	100	0.1	0.3
2030-0600	R1.5	6	27,500	275	140	0.125	0.33	11,000	280	140	0.38	0.15	24,000	240	120	0.125	0.33
2030-0800		8	27,500	275	140	0.125	0.33	11,000	280	140	0.38	0.15	24,000	240	120	0.125	0.33
2030-1000		10	27,500	275	140	0.125	0.33	11,000	280	140	0.3	0.15	24,000	240	120	0.125	0.33
2030-1200		12	27,500	220	110	0.125	0.33	11,000	280	140	0.3	0.15	24,000	200	100	0.125	0.33
2030-1400		14	27,500	220	110	0.125	0.33	11,000	280	140	0.3	0.15	24,000	200	100	0.125	0.33
2040-0800	R2	8	24,000	240	120	0.15	0.35	8,250	300	150	0.5	0.2	24,000	240	120	0.15	0.35
2040-1000		10	24,000	240	120	0.15	0.35	8,250	300	150	0.5	0.2	24,000	240	120	0.15	0.35
2040-1500		15	24,000	240	120	0.15	0.35	8,250	300	150	0.5	0.2	24,000	240	120	0.15	0.35
2050-1000	R2.5	10	22,000	220	110	0.175	0.37	6,600	330	160	0.6	0.25	22,000	220	110	0.175	0.37
2050-1500		15	22,000	220	110	0.175	0.37	6,600	330	160	0.6	0.25	22,000	220	110	0.175	0.37
2060-1000	R3	10	20,000	200	100	0.2	0.4	5,500	280	140	0.65	0.28	20,000	200	100	0.2	0.4
2060-1500		15	20,000	200	100	0.2	0.4	5,500	280	140	0.65	0.28	20,000	200	100	0.2	0.4

\*Feed Rate2: Feed rate of approach and \*connection moves.

\*Changing from one engagement point to the next.

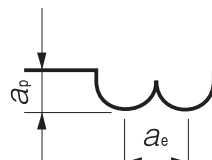

## UDCLB R0.5 × EL2

Hexalobular milling

Cemented Carbide  
VF-20 (92.5 HRA)



Size :  $\varnothing 9 \times$  Depth 3.5 mm

### Milling condition

Tool	UDCLB 2010-0200 (R0.5 × 2)
Spindle Speed	$n=30,000 \text{ min}^{-1}$
Feed Rate	$V_f=300 \text{ mm/min}$
Milling Amount	$a_p=0.05 \text{ mm}$ $a_e=0.30 \text{ mm}$ (Bottom Surface $a_e=0.05 \text{ mm}$ )
Coolant	Air Blow
Cycle Time	64.5 min
Material Removal Volume	$164.6 \text{ mm}^3$ $2.57 \text{ mm}^3/\text{min}$

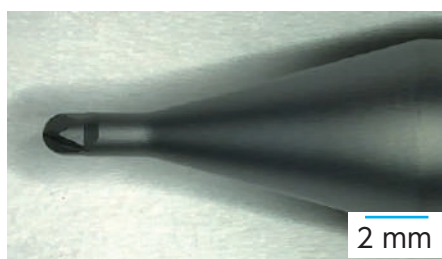
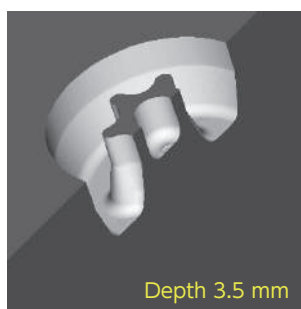

UDCLB Hexalobular Milling Video

## UDCLB R0.5

Hexalobular milling

Cemented Carbide  
VF-20 (92.5 HRA)



Size :  
 $\varnothing 9 \times$  Depth 6 mm



### Milling condition

Tool	UDCLB 2010-0200 (R0.5 × 2) UDCLB 2010-0500 (R0.5 × 5)
Feed Rate	$n=30,000 \text{ min}^{-1}$
Milling Amount	$V_f=300 \text{ mm/min}$ ① R 0.5 × 2 Roughing (Depth 3.5 mm) $a_p=0.05 \text{ mm}$ $a_e=0.3 \text{ mm}$ ② R0.5 × 5 Roughing (Depth 6 mm) $a_p=0.05 \text{ mm}$ $a_e=0.25 \text{ mm}$ ③ R0.5 × 5 Finishing $a_p=0.03 \text{ mm}$ $a_e=0.005 \text{ mm}$
Coolant	Air Blow
Cycle Time	156 min
Material Removal Volume	$274.4 \text{ mm}^3$

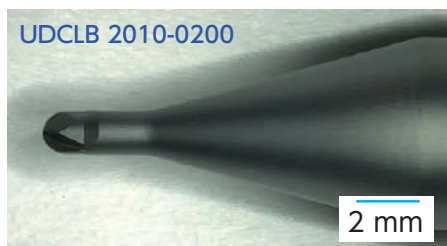

• Tool #1 milled depth 3.5 mm.



• Tool #2 milled  $131.9 \text{ mm}^3$  in 76.5 minutes.

# UPDLB



1 Flute Binderless PCD Long Neck Ball End Mills for Finishing Cemented Carbide and Hard Brittle Materials

R0.1~R1



Material Applications (★ Highly Recommended ● Recommended ○ Suggested)

Work Material																	
CARBON STEELS S45C S55C	ALLOY STEELS SK / SCM SUS	PREHARDENED STEELS NAK HPM	HARDENED STEELS					CAST IRON	ALUMINUM ALLOYS	GRAPHITE	COPPER	PLASTICS	GLASS FILLED PLASTICS	TITANIUM ALLOYS	HEAT RESISTANT ALLOYS	CEMENTED CARBIDE	HARD BRITTLE (NON-METALLIC) MATERIALS
			~ 50 HRC	~ 55 HRC	~ 60 HRC	~ 65 HRC	~ 70 HRC										
															★	●	

## Features

### Binderless PCD

Provides excellent machined surface quality due to the sharp cutting edge and optimized edge treatment.

Maintains excellent dimensional accuracy for a long time due to the high contour accuracy of the cutting edge and the excellent wear resistance of diamonds.

### Label Sample



Diameter and Ball Radius accuracy measurements are printed on the label to support High Precision milling.

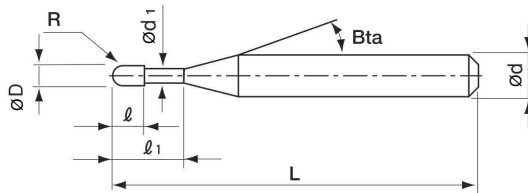

Be sure to confirm the interference between the inclined work piece and the shank part by actual measurement.

Total 5 models

Unit (mm)

Model Number	Radius of Ball Nose R	Effective Length $l_1$	Length of Cut $l$	Neck Diameter $\phi d_1$	Shank Taper Angle Bta	Overall Length L	Shank Diameter $\phi d$	Series
UPDLB 1002-004	R0.1	0.4	0.1	0.18	16°	40	4	UPDLB
UPDLB 1004-008	R0.2	0.8	0.2	0.38	16°	40	4	UPDLB
UPDLB 1006-010	R0.3	1	0.3	0.58	16°	40	4	UPDLB
UPDLB 1010-020	R0.5	2	0.5	0.95	16°	40	4	UPDLB
UPDLB 1020-030	R1	3	1	1.95	16°	40	4	UPDLB



For finishing of bottom surface

WORK MATERIAL			CEMENTED CARBIDE			
Model Number	Radius of Ball Nose (mm)	Effective Length (mm)	Spindle Speed (min <sup>-1</sup> )	Feed Rate (mm/min)	a <sub>p</sub> Axial Depth (mm)	a <sub>e</sub> Radial Depth (mm)
1002-004	R0.1	0.4	40,000	100	0.001	0.001
1004-008	R0.2	0.8	40,000	150	0.001	0.001
1006-010	R0.3	1	40,000	200	0.001	0.001
1010-020	R0.5	2	40,000	400	0.001	0.003
1020-030	R1	3	40,000	600	0.001	0.005

For profile milling

WORK MATERIAL			CEMENTED CARBIDE			
Model Number	Radius of Ball Nose (mm)	Effective Length (mm)	Spindle Speed (min <sup>-1</sup> )	Feed Rate (mm/min)	a <sub>p</sub> Axial Depth (mm)	a <sub>e</sub> Radial Depth (mm)
1002-004	R0.1	0.4	40,000	100	0.001	0.001
1004-008	R0.2	0.8	40,000	150	0.002	0.001
1006-010	R0.3	1	40,000	200	0.003	0.001
1010-020	R0.5	2	40,000	400	0.005	0.003
1020-030	R1	3	40,000	600	0.01	0.005

Note:

- Use a machine with high accuracy for stable cutting.
- Non-water soluble coolant recommended. Supply as a mist or external coolant. Take fire prevention precautions to avoid fire hazards caused by sparks igniting during machining or tool breakage.
- Shorten overhang as much as possible.
- Adjust cutting conditions as necessary as machine spec and other conditions may vary.
- These cutting parameters show reference value. Adjust the cutting conditions to the desired machined surface finish.

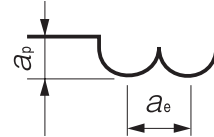

UDCBF / UPDLB R0.5

UPDLB Milling Example for Finishing

Cemented Carbide  
VF-20 (92.5 HRA)

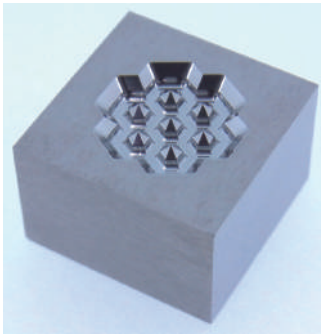

Milling Area : 10.2 × 10.2 × Depth 1.4 mm

Work Size : 20 × 20 × 10 mm

After Finishing



Milling Process	Tool	Spindle Speed (min <sup>-1</sup> )	Feed Rate (mm/min)	a <sub>p</sub> Axial Depth (mm)	a <sub>e</sub> Radial Depth (mm)	Allowance (mm)	Coolant	Cycle Time (h:m:s)
Roughing	UDCBF 2010-0070 (R0.5 × L0.7)	30,000	300	0.05	0.25	0.005	Air Blow	30 min
Semi-finishing		30,000	300	0.001 (Cusp Height)	0.06321	0.005		12 min
Finishing	UPDLB 1010-020 (R0.5 × EL2)	40,000	400	0.0035	0.00495	0	Oil Mist	1h 30 min

# UDCLRSH

NEW



2 Flute High-speed Long Neck Radius End Mills for Cemented Carbide and Hard Brittle Materials

Ø0.5~Ø2



Material Applications (★ Highly Recommended ● Recommended ○ Suggested)

Work Material																	
CARBON STEELS S45C S55C	ALLOY STEELS SK / SCM SUS	PREHARDENED STEELS NAK HPM	HARDENED STEELS					CAST IRON	ALUMINUM ALLOYS	GRAPHITE	COPPER	PLASTICS	GLASS FILLED PLASTICS	TITANIUM ALLOYS	HEAT RESISTANT ALLOYS	CEMENTED CARBIDE	HARD BRITTLE (NON-METALLIC) MATERIALS
			~ 50 HRC	~ 55 HRC	~ 60 HRC	~ 65 HRC	~ 70 HRC										
												○			★	●	

※Hard Brittle (Non-Metallic) Materials: Ceramics (Alumina, Zirconia,etc.), Glasses and etc.



For high efficiency roughing and semi-finishing

Label Sample



#001 ØD1.993 R0.000/-0.001

Diameter and Corner R accuracy measurements are printed on the label to support High Precision milling.

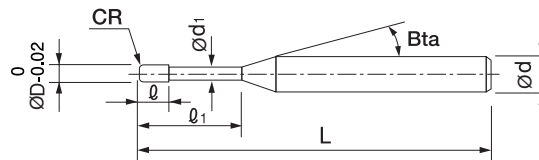

The shank taper angle shown is not an exact value.

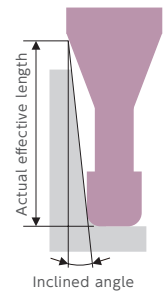

Total 38 models

Unit (mm)

Model Number	Outside Diameter ØD	Corner Radius CR	Effective Length $l_1$	Length of Cut $l$	Neck Diameter Ød <sub>1</sub>	Shank Taper Angle Bta	Overall Length L	Shank Diameter Ød	Series	Effective Length by Inclined Angles				
										30°	1°	1°30'	2°	3°
UDCLRSH 2005-003005	0.5	R0.03	0.5	0.25	0.46	16°	50	4	UDCLRSH	0.55	0.56	0.58	0.60	0.64
UDCLRSH 2005-003010			1				50	4	UDCLRSH	1.06	1.10	1.13	1.17	1.25
UDCLRSH 2005-003015			1.5				50	4	UDCLRSH	1.58	1.63	1.68	1.74	1.87
UDCLRSH 2005-005005		R0.05	0.5				50	4	UDCLRSH	0.55	0.56	0.58	0.60	0.64
UDCLRSH 2005-005010			1				50	4	UDCLRSH	1.06	1.09	1.13	1.17	1.25
UDCLRSH 2005-005015			1.5				50	4	UDCLRSH	1.58	1.63	1.68	1.74	1.86
UDCLRSH 2008-003010	0.8	R0.03	1	0.4	0.76	16°	50	4	UDCLRSH	1.06	1.10	1.13	1.17	1.25
UDCLRSH 2008-003020			2				50	4	UDCLRSH	2.09	2.16	2.23	2.31	2.48
UDCLRSH 2008-005010			R0.05				1	50	4	UDCLRSH	1.06	1.09	1.13	1.17
UDCLRSH 2008-005020		2					50	4	UDCLRSH	2.09	2.16	2.23	2.31	2.47
UDCLRSH 2008-010010		R0.1					1	50	4	UDCLRSH	1.06	1.09	1.12	1.16
UDCLRSH 2008-010020			2				50	4	UDCLRSH	2.09	2.16	2.22	2.30	2.46
UDCLRSH 2010-003010	1	R0.03	1	0.5	0.96	16°	50	4	UDCLRSH	1.06	1.10	1.13	1.17	1.25
UDCLRSH 2010-003020			2				50	4	UDCLRSH	2.09	2.16	2.23	2.31	2.48
UDCLRSH 2010-003040			4				50	4	UDCLRSH	4.16	4.29	4.43	4.59	4.93
UDCLRSH 2010-005010		R0.05	1				50	4	UDCLRSH	1.06	1.09	1.13	1.17	1.25
UDCLRSH 2010-005020			2				50	4	UDCLRSH	2.09	2.16	2.23	2.31	2.47
UDCLRSH 2010-005040			4				50	4	UDCLRSH	4.15	4.29	4.43	4.58	4.92
UDCLRSH 2010-010010		R0.1	1				50	4	UDCLRSH	1.06	1.09	1.12	1.16	1.24
UDCLRSH 2010-010020			2				50	4	UDCLRSH	2.09	2.16	2.22	2.30	2.46
UDCLRSH 2010-010040			4				50	4	UDCLRSH	4.15	4.28	4.43	4.58	4.91

2 Flute High-speed Long Neck Radius End Mills for Cemented Carbide and Hard Brittle Materials

Model Number	Outside Diameter ØD	Corner Radius CR	Effective Length $l_1$	Length of Cut $l$	Neck Diameter Ød <sub>1</sub>	Shank Taper Angle Bta	Overall Length L	Shank Diameter Ød	Series	Effective Length by Inclined Angles				
										30°	1°	1°30'	2°	3°
UDCLRSRSH 2015-005015	1.5	R0.05	1.5	0.75	1.44	16°	50	4	UDCLRSRSH	1.61	1.66	1.72	1.78	1.90
UDCLRSRSH 2015-005030			3				50	4	UDCLRSRSH	3.16	3.26	3.37	3.48	3.74
UDCLRSRSH 2015-010015		R0.1	1.5				50	4	UDCLRSRSH	1.61	1.66	1.71	1.77	1.89
UDCLRSRSH 2015-010030			3				50	4	UDCLRSRSH	3.16	3.26	3.36	3.48	3.73
UDCLRSRSH 2015-010040			4				50	4	UDCLRSRSH	4.19	4.32	4.46	4.62	4.95
UDCLRSRSH 2020-003020			R0.03				2	50	4	UDCLRSRSH	2.20	2.27	2.35	2.43
UDCLRSRSH 2020-003040	4	50		4	UDCLRSRSH	4.26	4.40	4.55	4.70	5.05				
UDCLRSRSH 2020-005020	2	R0.05	2	1	1.9	16°	50	4	UDCLRSRSH	2.20	2.27	2.34	2.42	2.60
UDCLRSRSH 2020-005040			4				50	4	UDCLRSRSH	4.26	4.40	4.55	4.70	5.05
UDCLRSRSH 2020-005060			6				50	4	UDCLRSRSH	6.33	6.53	6.75	6.98	7.50
UDCLRSRSH 2020-005080			8				50	4	UDCLRSRSH	8.39	8.66	8.95	9.26	9.94
UDCLRSRSH 2020-005100		10	50				4	UDCLRSRSH	10.45	10.79	11.15	11.53	12.39	
UDCLRSRSH 2020-010020		R0.1	2				50	4	UDCLRSRSH	2.20	2.27	2.34	2.42	2.59
UDCLRSRSH 2020-010040			4				50	4	UDCLRSRSH	4.26	4.40	4.54	4.69	5.04
UDCLRSRSH 2020-010060			6				50	4	UDCLRSRSH	6.32	6.53	6.74	6.97	7.49
UDCLRSRSH 2020-010080	8		50	4	UDCLRSRSH	8.39	8.66	8.94	9.25	9.93				
UDCLRSRSH 2020-010100	10		50	4	UDCLRSRSH	10.45	10.79	11.14	11.53	12.38				

Comparison of material removal volume  
 UDCLRSF / UDCLRSRSH  $\phi 0.5 \times CR0.03 \times EL0.5$

Cemented Carbide  
 VM-40 (90 HRA)

Tool	UDCLRSF	UDCLRSRSH
Spindle Speed	20,000 min <sup>-1</sup>	
Feed Rate	190 mm/min	380 mm/min
$a_p$ Axial Depth	0.02 mm	
$a_e$ Radial Depth	0.4 mm	
Tool life expectancy	2 h	3 h

Milling method : Flat milling

Coolant : Air blow

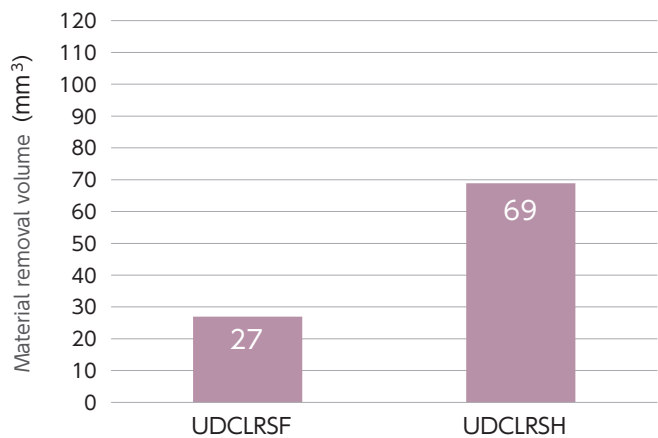

Milling efficiency and material removal volume exceeds the conventional tool.

WORK MATERIAL		CEMENTED CARBIDE (≥87 HRA) / HARD BRITTLE MATERIALS												
Model Number	Spindle Speed (min <sup>-1</sup> )	Z-Level Milling				Flat Milling			Side Milling			Slotting		
		Feed Rate (mm/min)	*Feed Rate2 (mm/min)	a <sub>p</sub> Axial Depth (mm)	a <sub>e</sub> Radial Depth (mm)	Feed Rate (mm/min)	a <sub>p</sub> Axial Depth (mm)	a <sub>e</sub> Radial Depth (mm)	Feed Rate (mm/min)	a <sub>p</sub> Axial Depth (mm)	a <sub>e</sub> Radial Depth (mm)	Feed Rate (mm/min)	a <sub>p</sub> Axial Depth (mm)	
2005-003005	30,000	380	180	0.02	0.4	380	0.02	0.4	360	0.25	0.01	380	0.02	
2005-003010	30,000	380	180	0.02	0.4	380	0.02	0.4	360	0.125	0.01	380	0.02	
2005-003015	30,000	300	140	0.015	0.3	300	0.015	0.3	290	0.125	0.007	300	0.015	
2005-005005	30,000	380	250	0.02	0.4	380	0.02	0.4	360	0.25	0.01	380	0.02	
2005-005010	30,000	380	250	0.02	0.4	380	0.02	0.4	360	0.125	0.01	380	0.02	
2005-005015	30,000	300	140	0.015	0.3	300	0.015	0.3	290	0.125	0.007	300	0.015	
2008-003010	30,000	380	180	0.02	0.6	380	0.02	0.6	600	0.4	0.016	380	0.02	
2008-003020	30,000	380	180	0.02	0.6	380	0.02	0.6	600	0.2	0.01	380	0.02	
2008-005010	30,000	380	300	0.025	0.6	380	0.025	0.6	600	0.4	0.016	380	0.025	
2008-005020	30,000	380	300	0.025	0.6	380	0.025	0.6	600	0.2	0.01	380	0.025	
2008-010010	30,000	380	300	0.03	0.6	380	0.03	0.6	600	0.4	0.016	380	0.03	
2008-010020	30,000	380	300	0.03	0.6	380	0.03	0.6	600	0.2	0.01	380	0.03	
2010-003010	30,000	380	180	0.02	0.8	380	0.02	0.8	750	0.5	0.02	380	0.02	
2010-003020	30,000	380	180	0.02	0.8	380	0.02	0.8	750	0.25	0.01	380	0.02	
2010-003040	30,000	230	110	0.016	0.6	230	0.016	0.6	450	0.25	0.005	230	0.016	
2010-005010	30,000	380	370	0.025	0.8	380	0.025	0.8	750	0.5	0.02	380	0.025	
2010-005020	30,000	380	370	0.025	0.8	380	0.025	0.8	750	0.25	0.01	380	0.025	
2010-005040	30,000	230	220	0.02	0.6	230	0.02	0.6	450	0.25	0.005	230	0.02	
2010-010010	30,000	380	370	0.03	0.8	380	0.03	0.8	750	0.5	0.02	380	0.03	
2010-010020	30,000	380	370	0.03	0.8	380	0.03	0.8	750	0.25	0.01	380	0.03	
2010-010040	30,000	230	220	0.025	0.6	230	0.025	0.6	450	0.25	0.005	230	0.025	
2015-005015	25,000	380	250	0.04	1.3	380	0.04	1.3	750	0.75	0.02	380	0.04	
2015-005030	25,000	380	250	0.04	1.3	380	0.04	1.3	750	0.375	0.01	380	0.04	
2015-010015	25,000	380	300	0.045	1.3	380	0.045	1.3	750	0.75	0.02	380	0.045	
2015-010030	25,000	380	300	0.045	1.3	380	0.045	1.3	750	0.375	0.01	380	0.045	
2015-010040	25,000	350	280	0.043	1.2	350	0.043	1.2	680	0.375	0.008	350	0.043	
2020-003020	20,000	380	180	0.04	1.8	380	0.04	1.8	750	1	0.02	380	0.04	
2020-003040	20,000	380	180	0.04	1.8	380	0.04	1.8	750	0.5	0.01	380	0.04	
2020-005020	20,000	380	180	0.05	1.8	380	0.05	1.8	750	1	0.02	380	0.05	
2020-005040	20,000	380	180	0.05	1.8	380	0.05	1.8	750	0.5	0.01	380	0.05	
2020-005060	20,000	300	140	0.045	1.7	300	0.045	1.7	600	0.5	0.007	300	0.045	
2020-005080	20,000	230	110	0.04	1.5	230	0.04	1.5	450	0.5	0.005	230	0.04	
2020-005100	20,000	190	90	0.028	1.3	190	0.028	1.3	300	0.5	0.005	190	0.028	
2020-010020	20,000	380	250	0.06	1.8	380	0.06	1.8	750	1	0.02	380	0.06	
2020-010040	20,000	380	250	0.06	1.8	380	0.06	1.8	750	0.5	0.01	380	0.06	
2020-010060	20,000	300	200	0.055	1.7	300	0.055	1.7	600	0.5	0.007	300	0.055	
2020-010080	20,000	230	150	0.045	1.5	230	0.045	1.5	450	0.5	0.005	230	0.045	
2020-010100	20,000	190	125	0.033	1.3	190	0.033	1.3	300	0.5	0.005	190	0.033	

WORK MATERIAL	CEMENTED CARBIDE (<87 HRA)													
	Model Number	Spindle Speed (min <sup>-1</sup> )	Z-Level Milling				Flat Milling			Side Milling			Slotting	
			Feed Rate (mm/min)	*Feed Rate2 (mm/min)	a <sub>p</sub> Axial Depth (mm)	a <sub>e</sub> Radial Depth (mm)	Feed Rate (mm/min)	a <sub>p</sub> Axial Depth (mm)	a <sub>e</sub> Radial Depth (mm)	Feed Rate (mm/min)	a <sub>p</sub> Axial Depth (mm)	a <sub>e</sub> Radial Depth (mm)	Feed Rate (mm/min)	a <sub>p</sub> Axial Depth (mm)
2005-003005	16,000	750	240	0.02	0.4	750	0.02	0.4	800	0.25	0.008	750	0.02	
2005-003010	16,000	750	240	0.02	0.4	750	0.02	0.4	400	0.125	0.008	750	0.02	
2005-003015	16,000	490	150	0.014	0.3	490	0.014	0.3	300	0.125	0.007	490	0.014	
2005-005005	16,000	750	240	0.025	0.4	750	0.025	0.4	800	0.25	0.008	750	0.025	
2005-005010	16,000	750	240	0.025	0.4	750	0.025	0.4	400	0.125	0.008	750	0.025	
2005-005015	16,000	490	150	0.017	0.3	490	0.017	0.3	300	0.125	0.007	490	0.017	
2008-003010	13,000	585	200	0.02	0.6	585	0.02	0.6	1,200	0.4	0.012	585	0.02	
2008-003020	13,000	585	200	0.02	0.6	585	0.02	0.6	600	0.2	0.012	585	0.02	
2008-005010	13,000	585	200	0.025	0.6	585	0.025	0.6	1,200	0.4	0.012	585	0.025	
2008-005020	13,000	585	200	0.025	0.6	585	0.025	0.6	600	0.2	0.012	585	0.025	
2008-010010	13,000	585	200	0.03	0.6	585	0.03	0.6	1,200	0.4	0.012	585	0.03	
2008-010020	13,000	585	200	0.03	0.6	585	0.03	0.6	600	0.2	0.012	585	0.03	
2010-003010	12,000	540	180	0.02	0.8	540	0.02	0.8	1,440	0.5	0.015	540	0.02	
2010-003020	12,000	540	180	0.02	0.8	540	0.02	0.8	720	0.25	0.015	540	0.02	
2010-003040	10,000	360	120	0.012	0.7	360	0.012	0.7	600	0.25	0.01	360	0.012	
2010-005010	12,000	540	180	0.025	0.8	540	0.025	0.8	1,440	0.5	0.015	540	0.025	
2010-005020	12,000	540	180	0.025	0.8	540	0.025	0.8	720	0.25	0.015	540	0.025	
2010-005040	10,000	360	120	0.015	0.7	360	0.015	0.7	600	0.25	0.01	360	0.015	
2010-010010	12,000	540	180	0.03	0.8	540	0.03	0.8	1,440	0.5	0.015	540	0.03	
2010-010020	12,000	540	180	0.03	0.8	540	0.03	0.8	720	0.25	0.015	540	0.03	
2010-010040	10,000	360	120	0.02	0.7	360	0.02	0.7	600	0.25	0.01	360	0.02	
2015-005015	11,000	495	170	0.04	1.3	495	0.04	1.3	1,440	0.75	0.015	495	0.04	
2015-005030	11,000	495	170	0.04	1.3	495	0.04	1.3	720	0.375	0.015	495	0.04	
2015-010015	11,000	495	170	0.045	1.3	495	0.045	1.3	1,440	0.75	0.015	495	0.045	
2015-010030	11,000	495	170	0.045	1.3	495	0.045	1.3	720	0.375	0.015	495	0.045	
2015-010040	11,000	460	150	0.045	1.1	460	0.045	1.1	720	0.375	0.014	460	0.045	
2020-003020	10,000	450	150	0.04	1.8	450	0.04	1.8	1,440	1	0.015	450	0.04	
2020-003040	10,000	450	150	0.04	1.8	450	0.04	1.8	1,440	1	0.015	450	0.04	
2020-005020	10,000	450	150	0.05	1.8	450	0.05	1.8	1,440	1	0.015	450	0.05	
2020-005040	10,000	450	150	0.05	1.8	450	0.05	1.8	1,440	1	0.015	450	0.05	
2020-005060	10,000	390	130	0.045	1.6	390	0.045	1.6	1,440	0.5	0.013	390	0.045	
2020-005080	10,000	360	120	0.028	1.6	360	0.028	1.6	1,440	0.5	0.011	360	0.028	
2020-005100	10,000	300	100	0.02	1.6	300	0.02	1.6	1,440	0.5	0.009	300	0.02	
2020-010020	10,000	450	150	0.06	1.8	450	0.06	1.8	1,440	1	0.015	450	0.06	
2020-010040	10,000	450	150	0.06	1.8	450	0.06	1.8	1,440	1	0.015	450	0.06	
2020-010060	10,000	390	130	0.054	1.6	390	0.054	1.6	1,440	0.5	0.013	390	0.054	
2020-010080	10,000	360	120	0.034	1.6	360	0.034	1.6	1,440	0.5	0.011	360	0.034	
2020-010100	10,000	300	100	0.023	1.6	300	0.023	1.6	1,440	0.5	0.009	300	0.023	

\* Feed Rate2: Feed rate of approach and \*connection moves.

\*Changing from one engagement point to the next.

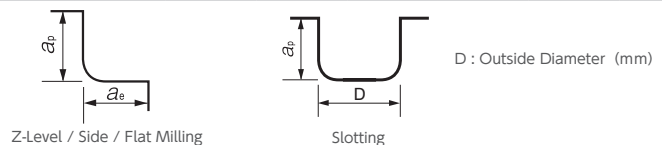

# UDCLRSF



2 Flute High-grade Long Neck Radius End Mills for Cemented Carbide and Hard Brittle Materials

Ø0.25~Ø2



Material Applications (★ Highly Recommended ● Recommended ○ Suggested)

Work Material																	
CARBON STEELS S45C S55C	ALLOY STEELS SK / SCM SUS	PREHARDENED STEELS NAK HPM	HARDENED STEELS					CAST IRON	ALUMINUM ALLOYS	GRAPHITE	COPPER	PLASTICS	GLASS FILLED PLASTICS	TITANIUM ALLOYS	HEAT RESISTANT ALLOYS	CEMENTED CARBIDE	HARD BRITTLE (NON-METALLIC) MATERIALS
			~ 50 HRC	~ 55 HRC	~ 60 HRC	~ 65 HRC	~ 70 HRC										
												○			★	●	

※Hard Brittle (Non-Metallic) Materials: Ceramics (Alumina, Zirconia,etc.), Glasses and etc.



For excellent surface quality

Label Sample



#001 ØD1.990 R+0.001/-0.001

Diameter and Corner R accuracy measurements are printed on the label to support High Precision milling.

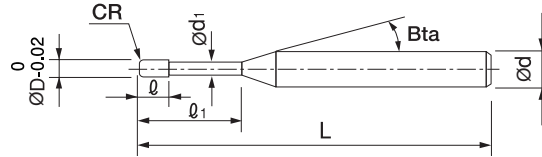

The shank taper angle shown is not an exact value.

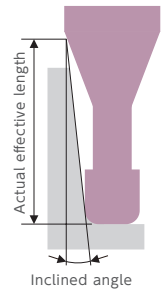

Total 58 models

Unit (mm)

Model Number	Outside Diameter ØD	Corner Radius CR	Effective Length $l_1$	Length of Cut $l$	Neck Diameter Ød <sub>1</sub>	Shank Taper Angle Bta	Overall Length L	Shank Diameter Ød	Series	Effective Length by Inclined Angles				
										30°	1°	1°30'	2°	3°
UDCLRSF 20025-003X5	0.25	R0.03	0.5	0.125	0.23	16°	50	4	UDCLRSF	0.51	0.53	0.54	0.56	0.60
UDCLRSF 20025-003X8			0.8				50	4	UDCLRSF	0.82	0.84	0.87	0.90	0.97
UDCLRSF 20025-005X5		R0.05	0.5				50	4	UDCLRSF	0.51	0.52	0.54	0.56	0.60
UDCLRSF 20025-005X8			0.8				50	4	UDCLRSF	0.82	0.84	0.87	0.90	0.96
UDCLRSF 2003-003006	0.3	R0.03	0.6	0.15	0.28	16°	50	4	UDCLRSF	0.61	0.63	0.65	0.67	0.72
UDCLRSF 2003-003009			0.9				50	4	UDCLRSF	0.92	0.95	0.98	1.02	1.09
UDCLRSF 2003-005006		R0.05	0.6				50	4	UDCLRSF	0.61	0.63	0.65	0.67	0.72
UDCLRSF 2003-005009			0.9				50	4	UDCLRSF	0.92	0.95	0.98	1.01	1.09
UDCLRSF 2005-003005	0.5	R0.03	0.5	0.25	0.46	16°	50	4	UDCLRSF	0.55	0.56	0.58	0.60	0.64
UDCLRSF 2005-003010			1				50	4	UDCLRSF	1.06	1.10	1.13	1.17	1.25
UDCLRSF 2005-003015			1.5				50	4	UDCLRSF	1.58	1.63	1.68	1.74	1.87
UDCLRSF 2005-005005		R0.05	0.5				50	4	UDCLRSF	0.55	0.56	0.58	0.60	0.64
UDCLRSF 2005-005010			1				50	4	UDCLRSF	1.06	1.09	1.13	1.17	1.25
UDCLRSF 2005-005015			1.5				50	4	UDCLRSF	1.58	1.63	1.68	1.74	1.86

2 Flute High-grade Long Neck Radius End Mills for Cemented Carbide and Hard Brittle Materials

Model Number	Outside Diameter ØD	Corner Radius CR	Effective Length ℓ <sub>1</sub>	Length of Cut ℓ	Neck Diameter Ød <sub>1</sub>	Shank Taper Angle Bta	Overall Length L	Shank Diameter Ød	Series	Effective Length by Inclined Angles				
										30°	1°	1°30'	2°	3°
UDCLRSF 2008-003008	0.8	R0.03	0.8	0.4	0.76	16°	50	4	UDCLRSF	0.86	0.88	0.91	0.94	1.01
UDCLRSF 2008-003016			1.6				50	4	UDCLRSF	1.68	1.73	1.79	1.85	1.99
UDCLRSF 2008-003024			2.4				50	4	UDCLRSF	2.51	2.59	2.67	2.76	2.97
UDCLRSF 2008-005008		R0.05	0.8				50	4	UDCLRSF	0.85	0.88	0.91	0.94	1.01
UDCLRSF 2008-005016			1.6				50	4	UDCLRSF	1.68	1.73	1.79	1.85	1.98
UDCLRSF 2008-005024			2.4				50	4	UDCLRSF	2.50	2.58	2.67	2.76	2.96
UDCLRSF 2008-010008		R0.1	0.8				50	4	UDCLRSF	0.85	0.88	0.90	0.93	0.99
UDCLRSF 2008-010016			1.6				50	4	UDCLRSF	1.68	1.73	1.78	1.84	1.97
UDCLRSF 2008-010024			2.4				50	4	UDCLRSF	2.50	2.58	2.66	2.75	2.95
UDCLRSF 2010-003010	1	R0.03	1	0.5	0.96	16°	50	4	UDCLRSF	1.06	1.10	1.13	1.17	1.25
UDCLRSF 2010-003020			2				50	4	UDCLRSF	2.09	2.16	2.23	2.31	2.48
UDCLRSF 2010-003040			4				50	4	UDCLRSF	4.16	4.29	4.43	4.59	4.93
UDCLRSF 2010-003060			6				50	4	UDCLRSF	6.22	6.42	6.63	6.86	7.37
UDCLRSF 2010-005010		R0.05	1				50	4	UDCLRSF	1.06	1.09	1.13	1.17	1.25
UDCLRSF 2010-005020			2				50	4	UDCLRSF	2.09	2.16	2.23	2.31	2.47
UDCLRSF 2010-005040			4				50	4	UDCLRSF	4.15	4.29	4.43	4.58	4.92
UDCLRSF 2010-005060			6				50	4	UDCLRSF	6.22	6.42	6.63	6.86	7.37
UDCLRSF 2010-010010		R0.1	1				50	4	UDCLRSF	1.06	1.09	1.12	1.16	1.24
UDCLRSF 2010-010020			2				50	4	UDCLRSF	2.09	2.16	2.22	2.30	2.46
UDCLRSF 2010-010040			4				50	4	UDCLRSF	4.15	4.28	4.43	4.58	4.91
UDCLRSF 2010-010060			6				50	4	UDCLRSF	6.22	6.41	6.63	6.85	7.36
UDCLRSF 2015-003015	1.5	R0.03	1.5	0.75	1.44	16°	50	4	UDCLRSF	1.61	1.66	1.72	1.78	1.91
UDCLRSF 2015-003030			3				50	4	UDCLRSF	3.16	3.26	3.37	3.49	3.74
UDCLRSF 2015-005015		R0.05	1.5				50	4	UDCLRSF	1.61	1.66	1.72	1.78	1.90
UDCLRSF 2015-005030			3				50	4	UDCLRSF	3.16	3.26	3.37	3.48	3.74
UDCLRSF 2015-010015		R0.1	1.5				50	4	UDCLRSF	1.61	1.66	1.71	1.77	1.89
UDCLRSF 2015-010030			3				50	4	UDCLRSF	3.16	3.26	3.36	3.48	3.73
UDCLRSF 2015-010040			4				50	4	UDCLRSF	4.19	4.32	4.46	4.62	4.95
UDCLRSF 2015-010060			6				50	4	UDCLRSF	6.25	6.45	6.66	6.89	7.40
UDCLRSF 2020-003020	2	R0.03	2	1	1.9	16°	50	4	UDCLRSF	2.20	2.27	2.35	2.43	2.61
UDCLRSF 2020-003040			4				50	4	UDCLRSF	4.26	4.40	4.55	4.70	5.05
UDCLRSF 2020-003060			6				50	4	UDCLRSF	6.33	6.53	6.75	6.98	7.50
UDCLRSF 2020-003080			8				50	4	UDCLRSF	8.39	8.66	8.95	9.26	9.95
UDCLRSF 2020-003100			10				50	4	UDCLRSF	10.45	10.79	11.15	11.54	12.40
UDCLRSF 2020-005020		R0.05	2				50	4	UDCLRSF	2.20	2.27	2.34	2.42	2.60
UDCLRSF 2020-005040			4				50	4	UDCLRSF	4.26	4.40	4.55	4.70	5.05
UDCLRSF 2020-005060			6				50	4	UDCLRSF	6.33	6.53	6.75	6.98	7.50
UDCLRSF 2020-005080			8				50	4	UDCLRSF	8.39	8.66	8.95	9.26	9.94
UDCLRSF 2020-005100			10				50	4	UDCLRSF	10.45	10.79	11.15	11.53	12.39
UDCLRSF 2020-010020		R0.1	2				50	4	UDCLRSF	2.20	2.27	2.34	2.42	2.59
UDCLRSF 2020-010040			4				50	4	UDCLRSF	4.26	4.40	4.54	4.69	5.04
UDCLRSF 2020-010060			6				50	4	UDCLRSF	6.32	6.53	6.74	6.97	7.49
UDCLRSF 2020-010080			8				50	4	UDCLRSF	8.39	8.66	8.94	9.25	9.93
UDCLRSF 2020-010100			10				50	4	UDCLRSF	10.45	10.79	11.14	11.53	12.38

WORK MATERIAL		CEMENTED CARBIDE (≥87 HRA) / HARD BRITTLE MATERIALS												
Model Number	Spindle Speed (min <sup>-1</sup> )	Z-Level Milling				Flat Milling			Side Milling			Slotting		
		Feed Rate (mm/min)	*Feed Rate2 (mm/min)	a <sub>p</sub> Axial Depth (mm)	a <sub>e</sub> Radial Depth (mm)	Feed Rate (mm/min)	a <sub>p</sub> Axial Depth (mm)	a <sub>e</sub> Radial Depth (mm)	Feed Rate (mm/min)	a <sub>p</sub> Axial Depth (mm)	a <sub>e</sub> Radial Depth (mm)	Feed Rate (mm/min)	a <sub>p</sub> Axial Depth (mm)	
20025-003X5	30,000	220	50	0.014	0.2	220	0.014	0.2	100	0.063	0.006	110	0.014	
20025-003X8	30,000	170	50	0.014	0.2	170	0.014	0.2	80	0.032	0.006	90	0.014	
20025-005X5	30,000	220	50	0.018	0.2	220	0.018	0.2	100	0.063	0.006	110	0.018	
20025-005X8	30,000	170	50	0.018	0.2	170	0.018	0.2	80	0.032	0.006	90	0.018	
2003-003006	30,000	220	50	0.015	0.2	220	0.015	0.2	110	0.075	0.006	110	0.015	
2003-003009	30,000	175	50	0.015	0.2	175	0.015	0.2	90	0.038	0.006	90	0.015	
2003-005006	30,000	220	50	0.02	0.2	220	0.02	0.2	110	0.075	0.006	110	0.02	
2003-005009	30,000	175	50	0.02	0.2	175	0.015	0.2	90	0.038	0.006	90	0.02	
2005-003005	30,000	190	90	0.02	0.4	190	0.02	0.4	180	0.25	0.01	190	0.02	
2005-003010	30,000	190	90	0.02	0.4	190	0.02	0.4	180	0.125	0.01	190	0.02	
2005-003015	30,000	140	65	0.015	0.3	140	0.015	0.3	130	0.125	0.007	140	0.015	
2005-005005	30,000	190	125	0.02	0.4	190	0.02	0.4	180	0.25	0.01	190	0.02	
2005-005010	30,000	190	125	0.02	0.4	190	0.02	0.4	180	0.125	0.01	190	0.02	
2005-005015	30,000	140	65	0.015	0.3	140	0.015	0.3	130	0.125	0.007	140	0.015	
2008-003008	30,000	190	90	0.02	0.6	190	0.02	0.6	300	0.4	0.016	190	0.02	
2008-003016	30,000	190	90	0.02	0.6	190	0.02	0.6	300	0.2	0.01	190	0.02	
2008-003024	30,000	175	80	0.018	0.5	175	0.018	0.5	275	0.2	0.007	175	0.018	
2008-005008	30,000	190	150	0.025	0.6	190	0.025	0.6	300	0.4	0.016	190	0.025	
2008-005016	30,000	190	150	0.025	0.6	190	0.025	0.6	300	0.2	0.01	190	0.025	
2008-005024	30,000	175	80	0.023	0.5	175	0.023	0.5	275	0.2	0.007	175	0.023	
2008-010008	30,000	190	150	0.03	0.6	190	0.03	0.6	300	0.4	0.016	190	0.03	
2008-010016	30,000	190	150	0.03	0.6	190	0.03	0.6	300	0.2	0.01	190	0.03	
2008-010024	30,000	175	80	0.028	0.5	175	0.028	0.5	275	0.2	0.007	175	0.028	
2010-003010	30,000	190	90	0.02	0.8	190	0.02	0.8	375	0.5	0.02	190	0.02	
2010-003020	30,000	190	90	0.02	0.8	190	0.02	0.8	375	0.25	0.01	190	0.02	
2010-003040	30,000	190	90	0.016	0.6	190	0.016	0.6	375	0.25	0.005	190	0.016	
2010-003060	25,000	155	75	0.01	0.5	155	0.01	0.5	300	0.25	0.005	155	0.01	
2010-005010	30,000	190	185	0.025	0.8	190	0.025	0.8	375	0.5	0.02	190	0.025	
2010-005020	30,000	190	185	0.025	0.8	190	0.025	0.8	375	0.25	0.01	190	0.025	
2010-005040	30,000	190	185	0.02	0.6	190	0.02	0.6	375	0.25	0.005	190	0.02	
2010-005060	25,000	155	150	0.012	0.5	155	0.012	0.5	300	0.25	0.005	155	0.012	
2010-010010	30,000	190	185	0.03	0.8	190	0.03	0.8	375	0.5	0.02	190	0.03	
2010-010020	30,000	190	185	0.03	0.8	190	0.03	0.8	375	0.25	0.01	190	0.03	
2010-010040	30,000	190	185	0.025	0.6	190	0.025	0.6	375	0.25	0.005	190	0.025	
2010-010060	25,000	155	150	0.015	0.5	155	0.015	0.5	300	0.25	0.005	155	0.015	



WORK MATERIAL	CEMENTED CARBIDE (<87 HRA)												
Model Number	Spindle Speed (min <sup>-1</sup> )	Z-Level Milling				Flat Milling			Side Milling			Slotting	
		Feed Rate (mm/min)	*Feed Rate2 (mm/min)	a <sub>p</sub> Axial Depth (mm)	a <sub>e</sub> Radial Depth (mm)	Feed Rate (mm/min)	a <sub>p</sub> Axial Depth (mm)	a <sub>e</sub> Radial Depth (mm)	Feed Rate (mm/min)	a <sub>p</sub> Axial Depth (mm)	a <sub>e</sub> Radial Depth (mm)	Feed Rate (mm/min)	a <sub>p</sub> Axial Depth (mm)
20025-003X5	24,000	300	50	0.014	0.2	300	0.014	0.2	200	0.063	0.003	300	0.014
20025-003X8	24,000	230	50	0.01	0.2	230	0.01	0.2	150	0.032	0.003	230	0.01
20025-005X5	24,000	300	50	0.018	0.2	300	0.018	0.2	200	0.063	0.003	300	0.018
20025-005X8	24,000	230	50	0.012	0.2	230	0.012	0.2	150	0.032	0.003	230	0.012
2003-003006	21,000	300	50	0.015	0.2	300	0.015	0.2	200	0.075	0.003	300	0.015
2003-003009	21,000	240	50	0.012	0.2	240	0.012	0.2	160	0.038	0.003	240	0.012
2003-005006	21,000	300	50	0.02	0.2	300	0.02	0.2	200	0.075	0.003	300	0.02
2003-005009	21,000	240	50	0.014	0.2	240	0.014	0.2	160	0.038	0.003	240	0.014
2005-003005	16,000	500	160	0.02	0.4	500	0.02	0.4	800	0.25	0.005	500	0.02
2005-003010	16,000	500	160	0.02	0.4	500	0.02	0.4	400	0.125	0.005	500	0.02
2005-003015	16,000	375	120	0.014	0.3	375	0.014	0.3	300	0.125	0.005	375	0.014
2005-005005	16,000	500	160	0.025	0.4	500	0.025	0.4	800	0.25	0.005	500	0.025
2005-005010	16,000	500	160	0.025	0.4	500	0.025	0.4	400	0.125	0.005	500	0.025
2005-005015	16,000	375	120	0.017	0.3	375	0.017	0.3	300	0.125	0.005	375	0.017
2008-003008	13,000	390	130	0.02	0.6	390	0.02	0.6	1,200	0.4	0.008	390	0.02
2008-003016	13,000	390	130	0.02	0.6	390	0.02	0.6	600	0.2	0.008	390	0.02
2008-003024	13,000	350	120	0.014	0.5	350	0.014	0.5	540	0.2	0.006	350	0.014
2008-005008	13,000	390	130	0.025	0.6	390	0.025	0.6	1,200	0.4	0.008	390	0.025
2008-005016	13,000	390	130	0.025	0.6	390	0.025	0.6	600	0.2	0.008	390	0.025
2008-005024	13,000	350	120	0.017	0.5	350	0.017	0.5	540	0.2	0.006	350	0.017
2008-010008	13,000	390	130	0.03	0.6	390	0.03	0.6	1,200	0.4	0.008	390	0.03
2008-010016	13,000	390	130	0.03	0.6	390	0.03	0.6	600	0.2	0.008	390	0.03
2008-010024	13,000	350	120	0.02	0.5	350	0.02	0.5	540	0.2	0.006	350	0.02
2010-003010	12,000	360	120	0.02	0.8	360	0.02	0.8	1,440	0.5	0.01	360	0.02
2010-003020	12,000	360	120	0.02	0.8	360	0.02	0.8	720	0.25	0.01	360	0.02
2010-003040	10,000	300	100	0.012	0.7	300	0.012	0.7	600	0.25	0.008	300	0.012
2010-003060	10,000	300	100	0.008	0.7	300	0.008	0.7	600	0.25	0.006	300	0.008
2010-005010	12,000	360	120	0.025	0.8	360	0.025	0.8	1,440	0.5	0.01	360	0.025
2010-005020	12,000	360	120	0.025	0.8	360	0.025	0.8	720	0.25	0.01	360	0.025
2010-005040	10,000	300	100	0.015	0.7	300	0.015	0.7	600	0.25	0.008	300	0.015
2010-005060	10,000	300	100	0.01	0.7	300	0.01	0.7	600	0.25	0.006	300	0.01
2010-010010	12,000	360	120	0.03	0.8	360	0.03	0.8	1,440	0.5	0.01	360	0.03
2010-010020	12,000	360	120	0.03	0.8	360	0.03	0.8	720	0.25	0.01	360	0.03
2010-010040	10,000	300	100	0.02	0.7	300	0.02	0.7	600	0.25	0.008	300	0.02
2010-010060	10,000	300	100	0.012	0.7	300	0.012	0.7	600	0.25	0.006	300	0.012

WORK MATERIAL		CEMENTED CARBIDE (≥87 HRA) / HARD BRITTLE MATERIALS												
Model Number	Spindle Speed (min <sup>-1</sup> )	Z-Level Milling				Flat Milling			Side Milling			Slotting		
		Feed Rate (mm/min)	※Feed Rate2 (mm/min)	a <sub>p</sub> Axial Depth (mm)	a <sub>e</sub> Radial Depth (mm)	Feed Rate (mm/min)	a <sub>p</sub> Axial Depth (mm)	a <sub>e</sub> Radial Depth (mm)	Feed Rate (mm/min)	a <sub>p</sub> Axial Depth (mm)	a <sub>e</sub> Radial Depth (mm)	Feed Rate (mm/min)	a <sub>p</sub> Axial Depth (mm)	
2015-003015	25,000	190	90	0.03	1.3	190	0.03	1.3	375	0.75	0.02	190	0.03	
2015-003030	25,000	190	90	0.03	1.3	190	0.03	1.3	375	0.375	0.01	190	0.03	
2015-005015	25,000	190	125	0.04	1.3	190	0.04	1.3	375	0.75	0.02	190	0.04	
2015-005030	25,000	190	125	0.04	1.3	190	0.04	1.3	375	0.375	0.01	190	0.04	
2015-010015	25,000	190	150	0.045	1.3	190	0.045	1.3	375	0.75	0.02	190	0.045	
2015-010030	25,000	190	150	0.045	1.3	190	0.045	1.3	375	0.375	0.01	190	0.045	
2015-010040	25,000	190	150	0.043	1.2	190	0.043	1.2	350	0.375	0.008	190	0.043	
2015-010060	25,000	190	150	0.04	1	190	0.04	1	350	0.375	0.005	190	0.04	
2020-003020	20,000	190	90	0.04	1.8	190	0.04	1.8	375	1	0.02	190	0.04	
2020-003040	20,000	190	90	0.04	1.8	190	0.04	1.8	375	0.5	0.01	190	0.04	
2020-003060	20,000	190	90	0.037	1.7	190	0.037	1.7	325	0.5	0.007	190	0.037	
2020-003080	20,000	190	90	0.03	1.5	190	0.03	1.5	325	0.5	0.005	190	0.03	
2020-003100	20,000	190	90	0.025	1.3	190	0.025	1.3	300	0.5	0.005	190	0.025	
2020-005020	20,000	190	90	0.05	1.8	190	0.05	1.8	375	1	0.02	190	0.05	
2020-005040	20,000	190	90	0.05	1.8	190	0.05	1.8	375	0.5	0.01	190	0.05	
2020-005060	20,000	190	90	0.045	1.7	190	0.045	1.7	325	0.5	0.007	190	0.045	
2020-005080	20,000	190	90	0.04	1.5	190	0.04	1.5	325	0.5	0.005	190	0.04	
2020-005100	20,000	190	90	0.028	1.3	190	0.028	1.3	300	0.5	0.005	190	0.028	
2020-010020	20,000	190	125	0.06	1.8	190	0.06	1.8	375	1	0.02	190	0.06	
2020-010040	20,000	190	125	0.06	1.8	190	0.06	1.8	375	0.5	0.01	190	0.06	
2020-010060	20,000	190	125	0.055	1.7	190	0.055	1.7	325	0.5	0.007	190	0.055	
2020-010080	20,000	190	125	0.045	1.5	190	0.045	1.5	325	0.5	0.005	190	0.045	
2020-010100	20,000	190	125	0.033	1.3	190	0.033	1.3	300	0.5	0.005	190	0.033	

WORK MATERIAL	CEMENTED CARBIDE (<87 HRA)													
Model Number	Spindle Speed (min <sup>-1</sup> )	Z-Level Milling				Flat Milling			Side Milling			Slotting		
		Feed Rate (mm/min)	*Feed Rate2 (mm/min)	a <sub>p</sub> Axial Depth (mm)	a <sub>e</sub> Radial Depth (mm)	Feed Rate (mm/min)	a <sub>p</sub> Axial Depth (mm)	a <sub>e</sub> Radial Depth (mm)	Feed Rate (mm/min)	a <sub>p</sub> Axial Depth (mm)	a <sub>e</sub> Radial Depth (mm)	Feed Rate (mm/min)	a <sub>p</sub> Axial Depth (mm)	
2015-003015	11,000	330	110	0.03	1.3	330	0.03	1.3	1,440	0.75	0.01	330	0.03	
2015-003030	11,000	330	110	0.03	1.3	330	0.03	1.3	720	0.375	0.01	330	0.03	
2015-005015	11,000	330	110	0.04	1.3	330	0.04	1.3	1,440	0.75	0.01	330	0.04	
2015-005030	11,000	330	110	0.04	1.3	330	0.04	1.3	720	0.375	0.01	330	0.04	
2015-010015	11,000	330	110	0.045	1.3	330	0.045	1.3	1,440	0.75	0.01	330	0.045	
2015-010030	11,000	330	110	0.045	1.3	330	0.045	1.3	720	0.375	0.01	330	0.045	
2015-010040	11,000	330	110	0.045	1.1	330	0.045	1.1	720	0.375	0.01	330	0.045	
2015-010060	11,000	330	110	0.03	1.1	330	0.03	1.1	720	0.375	0.009	330	0.03	
2020-003020	10,000	300	100	0.04	1.8	300	0.04	1.8	1,440	1	0.01	300	0.04	
2020-003040	10,000	300	100	0.04	1.8	300	0.04	1.8	1,440	1	0.01	300	0.04	
2020-003060	10,000	300	100	0.036	1.6	300	0.036	1.6	1,440	0.5	0.01	300	0.036	
2020-003080	10,000	300	100	0.023	1.6	300	0.023	1.6	1,440	0.5	0.009	300	0.023	
2020-003100	10,000	300	100	0.018	1.6	300	0.018	1.6	1,440	0.5	0.009	300	0.018	
2020-005020	10,000	300	100	0.05	1.8	300	0.05	1.8	1,440	1	0.01	300	0.05	
2020-005040	10,000	300	100	0.05	1.8	300	0.05	1.8	1,440	1	0.01	300	0.05	
2020-005060	10,000	300	100	0.045	1.6	300	0.045	1.6	1,440	0.5	0.01	300	0.045	
2020-005080	10,000	300	100	0.028	1.6	300	0.028	1.6	1,440	0.5	0.009	300	0.028	
2020-005100	10,000	300	100	0.02	1.6	300	0.02	1.6	1,440	0.5	0.009	300	0.02	
2020-010020	10,000	300	100	0.06	1.8	300	0.06	1.8	1,440	1	0.01	300	0.06	
2020-010040	10,000	300	100	0.06	1.8	300	0.06	1.8	1,440	1	0.01	300	0.06	
2020-010060	10,000	300	100	0.054	1.6	300	0.054	1.6	1,440	0.5	0.01	300	0.054	
2020-010080	10,000	300	100	0.034	1.6	300	0.034	1.6	1,440	0.5	0.009	300	0.034	
2020-010100	10,000	300	100	0.023	1.6	300	0.023	1.6	1,440	0.5	0.009	300	0.023	

\*Feed Rate2: Feed rate of approach and \*connection moves.

\*Changing from one engagement point to the next.

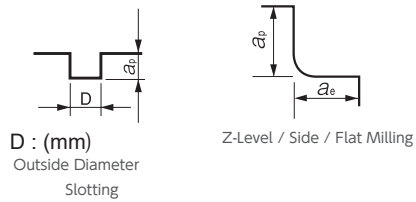

# UDCLRS



2 Flute Long Neck Radius End Mills for Cemented Carbide and Hard Brittle Materials

∅0.3~∅2



Material Applications (★ Highly Recommended ● Recommended ○ Suggested)

Work Material																	
CARBON STEELS S45C S55C	ALLOY STEELS SK / SCM SUS	PREHARDENED STEELS NAK HPM	HARDENED STEELS					CAST IRON	ALUMINUM ALLOYS	GRAPHITE	COPPER	PLASTICS	GLASS FILLED PLASTICS	TITANIUM ALLOYS	HEAT RESISTANT ALLOYS	CEMENTED CARBIDE	HARD BRITTLE (NON-METALLIC) MATERIALS
			~ 50 HRC	~ 55 HRC	~ 60 HRC	~ 65 HRC	~ 70 HRC										
												○ ※1			★	● ※2	

- ※ 1 UDCLRSF is highly recommended for Glass Filled Plastic milling.
- ※ 2 Hard Brittle (Non-Metallic) Materials: Ceramics (Alumina, Zirconia, etc.), Glasses and etc.

## Entry Series

For low-cost milling

Label Sample



#001 ∅D1.998 R+0.001/-0.001

Diameter and Corner R accuracy measurements are printed on the label to support High Precision milling.

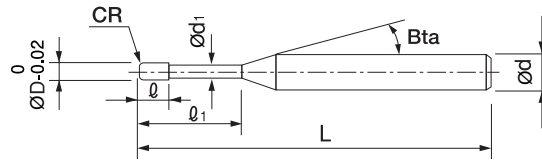

The shank taper angle shown is not an exact value.

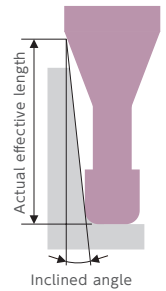

Total 30 models

Unit (mm)

Model Number	Outside Diameter ∅D	Corner Radius CR	Effective Length $l_1$	Length of Cut $l$	Neck Diameter ∅d <sub>1</sub>	Shank Taper Angle Bta	Overall Length L	Shank Diameter ∅d	Series	Effective Length by Inclined Angles				
										30'	1°	1°30'	2°	3°
UDCLRS 2003-003-006	0.3	R0.03	0.6	0.15	0.28	16°	50	4	UDCLRS	0.61	0.63	0.65	0.67	0.72
UDCLRS 2003-005-006		R0.05	0.6							0.61	0.63	0.65	0.67	0.72
UDCLRS 2005-003-005	0.5	R0.03	0.5	0.25	0.46	16°	50	4	UDCLRS	0.55	0.56	0.58	0.60	0.64
UDCLRS 2005-003-010			1							1.06	1.10	1.13	1.17	1.25
UDCLRS 2005-005-005		R0.05	0.5							0.55	0.56	0.58	0.60	0.64
UDCLRS 2005-005-010			1							1.06	1.09	1.13	1.17	1.25
UDCLRS 2008-003-008	0.8	R0.03	0.8	0.4	0.76	16°	50	4	UDCLRS	0.86	0.88	0.91	0.94	1.01
UDCLRS 2008-003-016			1.6							1.68	1.73	1.79	1.85	1.99
UDCLRS 2008-005-008		R0.05	0.8							0.85	0.88	0.91	0.94	1.01
UDCLRS 2008-005-016			1.6							1.68	1.73	1.79	1.85	1.98
UDCLRS 2008-010-008		R0.1	0.8							0.85	0.88	0.90	0.93	0.99
UDCLRS 2008-010-016			1.6							1.68	1.73	1.78	1.84	1.97
UDCLRS 2010-003-010	1	R0.03	1	0.5	0.96	16°	50	4	UDCLRS	1.06	1.10	1.13	1.17	1.25
UDCLRS 2010-003-020			2							2.09	2.16	2.23	2.31	2.48
UDCLRS 2010-005-010		R0.05	1							1.06	1.09	1.13	1.17	1.25
UDCLRS 2010-005-020			2							2.09	2.16	2.23	2.31	2.47
UDCLRS 2010-010-010		R0.1	1							1.06	1.09	1.12	1.16	1.24
UDCLRS 2010-010-020			2							2.09	2.16	2.22	2.30	2.46

2 Flute Long Neck Radius End Mills for Cemented Carbide and Hard Brittle Materials

Model Number	Outside Diameter ØD	Corner Radius CR	Effective Length $l_1$	Length of Cut $l$	Neck Diameter Ød <sub>1</sub>	Shank Taper Angle Bta	Overall Length L	Shank Diameter Ød	Series	Effective Length by Inclined Angles				
										30°	1°	1°30'	2°	3°
UDCLRS 2015-003-015	1.5	R0.03	1.5	0.75	1.44	16°	50	4	UDCLRS	1.61	1.66	1.72	1.78	1.91
UDCLRS 2015-003-030			3				50	4	UDCLRS	3.16	3.26	3.37	3.49	3.74
UDCLRS 2015-005-015		R0.05	1.5				50	4	UDCLRS	1.61	1.66	1.72	1.78	1.90
UDCLRS 2015-005-030			3				50	4	UDCLRS	3.16	3.26	3.37	3.48	3.74
UDCLRS 2015-010-015		R0.1	1.5				50	4	UDCLRS	1.61	1.66	1.71	1.77	1.89
UDCLRS 2015-010-030			3				50	4	UDCLRS	3.16	3.26	3.36	3.48	3.73
UDCLRS 2020-003-020	2	R0.03	2	1	1.9	16°	50	4	UDCLRS	2.20	2.27	2.35	2.43	2.61
UDCLRS 2020-003-040			4				50	4	UDCLRS	4.26	4.40	4.55	4.70	5.05
UDCLRS 2020-005-020		R0.05	2				50	4	UDCLRS	2.20	2.27	2.34	2.42	2.60
UDCLRS 2020-005-040			4				50	4	UDCLRS	4.26	4.40	4.55	4.70	5.05
UDCLRS 2020-010-020		R0.1	2				50	4	UDCLRS	2.20	2.27	2.34	2.42	2.59
UDCLRS 2020-010-040			4				50	4	UDCLRS	4.26	4.40	4.54	4.69	5.04

WORK MATERIAL	CEMENTED CARBIDE (≥87 HRA) / HARD BRITTLE MATERIALS													
Model Number	Spindle Speed (min <sup>-1</sup> )	Z-Level Milling				Flat Milling			Side Milling			Slotting		
		Feed Rate (mm/min)	*Feed Rate2 (mm/min)	a <sub>p</sub> Axial Depth (mm)	a <sub>e</sub> Radial Depth (mm)	Feed Rate (mm/min)	a <sub>p</sub> Axial Depth (mm)	a <sub>e</sub> Radial Depth (mm)	Feed Rate (mm/min)	a <sub>p</sub> Axial Depth (mm)	a <sub>e</sub> Radial Depth (mm)	Feed Rate (mm/min)	a <sub>p</sub> Axial Depth (mm)	
2003-003-006	30,000	220	50	0.01	0.2	220	0.01	0.2	110	0.05	0.001	110	0.01	
2003-005-006	30,000	220	50	0.01	0.2	220	0.01	0.2	110	0.05	0.001	110	0.01	
2005-003-005	30,000	185	90	0.01	0.4	185	0.01	0.4	375	0.25	0.005	375	0.01	
2005-003-010	30,000	185	90	0.01	0.4	185	0.01	0.4	180	0.125	0.005	375	0.01	
2005-005-005	30,000	375	125	0.01	0.4	375	0.01	0.4	375	0.25	0.005	375	0.01	
2005-005-010	30,000	375	125	0.01	0.4	375	0.01	0.4	180	0.125	0.005	375	0.01	
2008-003-008	30,000	185	90	0.01	0.6	185	0.01	0.6	600	0.4	0.008	375	0.01	
2008-003-016	30,000	185	90	0.01	0.6	185	0.01	0.6	300	0.2	0.008	375	0.01	
2008-005-008	30,000	375	150	0.01	0.6	375	0.01	0.6	600	0.4	0.008	375	0.01	
2008-005-016	30,000	375	150	0.01	0.6	375	0.01	0.6	300	0.2	0.008	375	0.01	
2008-010-008	30,000	375	150	0.01	0.6	375	0.01	0.6	600	0.4	0.008	375	0.01	
2008-010-016	30,000	375	150	0.01	0.6	375	0.01	0.6	300	0.2	0.008	375	0.01	
2010-003-010	30,000	185	90	0.01	0.8	185	0.01	0.8	750	0.5	0.01	375	0.01	
2010-003-020	30,000	185	90	0.01	0.8	185	0.01	0.8	375	0.25	0.01	375	0.01	
2010-005-010	30,000	375	185	0.01	0.8	375	0.01	0.8	750	0.5	0.01	375	0.01	
2010-005-020	30,000	375	185	0.01	0.8	375	0.01	0.8	375	0.25	0.01	375	0.01	
2010-010-010	30,000	375	185	0.01	0.8	375	0.01	0.8	750	0.5	0.01	375	0.01	
2010-010-020	30,000	375	185	0.01	0.8	375	0.01	0.8	375	0.25	0.01	375	0.01	
2015-003-015	25,000	185	90	0.01	1.3	185	0.01	1.3	750	0.75	0.01	375	0.015	
2015-003-030	25,000	185	90	0.01	1.3	185	0.01	1.3	375	0.375	0.01	375	0.015	
2015-005-015	25,000	375	125	0.015	1.3	375	0.015	1.3	750	0.75	0.01	375	0.015	
2015-005-030	25,000	375	125	0.015	1.3	375	0.015	1.3	375	0.375	0.01	375	0.015	
2015-010-015	25,000	375	150	0.015	1.3	375	0.015	1.3	750	0.75	0.01	375	0.015	
2015-010-030	25,000	375	150	0.015	1.3	375	0.015	1.3	375	0.375	0.01	375	0.015	
2020-003-020	20,000	185	90	0.01	1.8	185	0.01	1.8	750	1	0.01	375	0.02	
2020-003-040	20,000	185	90	0.01	1.8	185	0.01	1.8	375	0.5	0.01	375	0.02	
2020-005-020	20,000	375	90	0.02	1.8	375	0.02	1.8	750	1	0.01	375	0.02	
2020-005-040	20,000	375	90	0.02	1.8	375	0.02	1.8	375	0.5	0.01	375	0.02	
2020-010-020	20,000	375	125	0.02	1.8	375	0.02	1.8	750	1	0.01	375	0.02	
2020-010-040	20,000	375	125	0.02	1.8	375	0.02	1.8	375	0.5	0.01	375	0.02	

WORK MATERIAL	CEMENTED CARBIDE (<87 HRA)												
Model Number	Spindle Speed (min <sup>-1</sup> )	Z-Level Milling				Flat Milling			Side Milling			Slotting	
		Feed Rate (mm/min)	*Feed Rate2 (mm/min)	a <sub>p</sub> Axial Depth (mm)	a <sub>e</sub> Radial Depth (mm)	Feed Rate (mm/min)	a <sub>p</sub> Axial Depth (mm)	a <sub>e</sub> Radial Depth (mm)	Feed Rate (mm/min)	a <sub>p</sub> Axial Depth (mm)	a <sub>e</sub> Radial Depth (mm)	Feed Rate (mm/min)	a <sub>p</sub> Axial Depth (mm)
2003-003-006	21,000	220	50	0.01	0.2	220	0.01	0.2	200	0.075	0.003	200	0.01
2003-005-006	21,000	220	50	0.01	0.2	220	0.01	0.2	200	0.075	0.003	200	0.01
2005-003-005	20,000	275	135	0.02	0.4	275	0.02	0.4	800	0.25	0.005	550	0.02
2005-003-010	20,000	275	135	0.02	0.4	275	0.02	0.4	400	0.125	0.005	550	0.02
2005-005-005	20,000	550	180	0.02	0.4	550	0.02	0.4	800	0.25	0.005	550	0.02
2005-005-010	20,000	550	180	0.02	0.4	550	0.02	0.4	400	0.125	0.005	550	0.02
2008-003-008	19,000	290	145	0.02	0.6	290	0.02	0.6	1,200	0.4	0.008	580	0.025
2008-003-016	19,000	290	145	0.02	0.6	290	0.02	0.6	600	0.2	0.008	580	0.025
2008-005-008	19,000	580	190	0.025	0.6	580	0.025	0.6	1,200	0.4	0.008	580	0.025
2008-005-016	19,000	580	190	0.025	0.6	580	0.025	0.6	600	0.2	0.008	580	0.025
2008-010-008	19,000	580	190	0.025	0.6	580	0.025	0.6	1,200	0.4	0.008	580	0.025
2008-010-016	19,000	580	190	0.025	0.6	580	0.025	0.6	600	0.2	0.008	580	0.025
2010-003-010	18,250	300	150	0.02	0.8	300	0.02	0.8	1,440	0.5	0.01	600	0.025
2010-003-020	18,250	300	150	0.02	0.8	300	0.02	0.8	720	0.25	0.01	600	0.025
2010-005-010	18,250	600	200	0.025	0.8	600	0.025	0.8	1,440	0.5	0.01	600	0.025
2010-005-020	18,250	600	200	0.025	0.8	600	0.025	0.8	720	0.25	0.01	600	0.025
2010-010-010	18,250	600	200	0.025	0.8	600	0.025	0.8	1,440	0.5	0.01	600	0.025
2010-010-020	18,250	600	200	0.025	0.8	600	0.025	0.8	720	0.25	0.01	600	0.025
2015-003-015	16,500	325	160	0.02	1.3	325	0.02	1.3	1,440	0.75	0.01	650	0.035
2015-003-030	16,500	325	160	0.02	1.3	325	0.02	1.3	720	0.375	0.01	650	0.035
2015-005-015	16,500	650	210	0.035	1.3	650	0.035	1.3	1,440	0.75	0.01	650	0.035
2015-005-030	16,500	650	210	0.035	1.3	650	0.035	1.3	720	0.375	0.01	650	0.035
2015-010-015	16,500	650	210	0.035	1.3	650	0.035	1.3	1,440	0.75	0.01	650	0.035
2015-010-030	16,500	650	210	0.035	1.3	650	0.035	1.3	720	0.375	0.01	650	0.035
2020-003-020	15,000	360	180	0.02	1.8	360	0.02	1.8	1,440	1	0.01	720	0.05
2020-003-040	15,000	360	180	0.02	1.8	360	0.02	1.8	1,440	1	0.01	720	0.05
2020-005-020	15,000	720	240	0.05	1.8	720	0.05	1.8	1,440	1	0.01	720	0.05
2020-005-040	15,000	720	240	0.05	1.8	720	0.05	1.8	1,440	1	0.01	720	0.05
2020-010-020	15,000	720	240	0.05	1.8	720	0.05	1.8	1,440	1	0.01	720	0.05
2020-010-040	15,000	720	240	0.05	1.8	720	0.05	1.8	1,440	1	0.01	720	0.05

\*Feed Rate2: Feed rate of approach and \*connection moves.

\*Changing from one engagement point to the next.

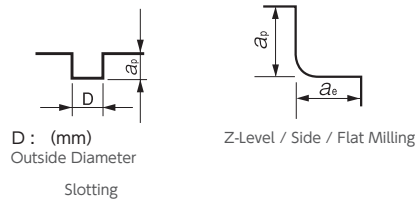

# UDCRRS



6 Flute / 10 Flute Long Neck Radius End Mills for Roughing Cemented Carbide and Hard Brittle Materials

Ø2~Ø6



Material Applications (★ Highly Recommended ● Recommended ○ Suggested)

Work Material																	
CARBON STEELS S45C S55C	ALLOY STEELS SK / SCM SUS	PREHARDENED STEELS NAK HPM	HARDENED STEELS					CAST IRON	ALUMINUM ALLOYS	GRAPHITE	COPPER	PLASTICS	GLASS FILLED PLASTICS	TITANIUM ALLOYS	HEAT RESISTANT ALLOYS	CEMENTED CARBIDE	HARD BRITTLE (NON-METALLIC) MATERIALS
			~ 50 HRC	~ 55 HRC	~ 60 HRC	~ 65 HRC	~ 70 HRC										
												○			★	●	

※Hard Brittle (Non-Metallic) Materials: Ceramics (Alumina, Zirconia, etc.), Glasses and etc.



Multi-flute Radius

Deep milling on axial depth

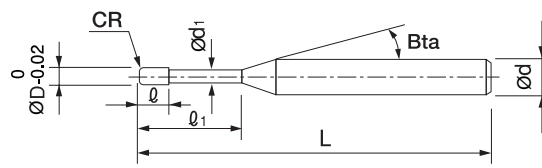

The shank taper angle shown is not an exact value.

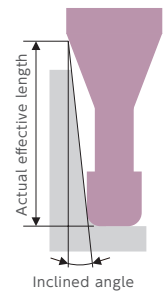

Total 4 models

Unit (mm)

Model Number	Outside Diameter ØD	Corner Radius CR	Effective Length $l_1$	Length of Cut $l$	Neck Diameter Ød <sub>1</sub>	Shank Taper Angle Bta	Overall Length L	Shank Diameter Ød	Number of Flutes	Series	Effective Length by Inclined Angles				
											30°	1°	1°30'	2°	3°
UDCRRS 6020-020-050	2	R0.2	5	1.6	1.77	16°	50	4	6	UDCRRS	5.52	5.70	5.88	6.08	6.52
UDCRRS 6030-020-075	3	R0.2	7.5	2.4	2.77	16°	60	6	6	UDCRRS	8.10	8.36	8.63	8.92	9.58
UDCRRS 6040-020-100	4	R0.2	10	3.2	3.77	16°	60	6	6	UDCRRS	10.68	11.02	11.38	11.77	12.64
UDCRRS 10060-020150	6	R0.2	15	4.8	5.77	16°	60	6	10	UDCRRS	No Interference	No Interference	No Interference	No Interference	No Interference

High Efficiency

Ø2~Ø4

6 Flutes



Ø6

10 Flutes



6 Flutes, 10 Flutes with a 40° helix angle help to reduce cutting load allowing for deep milling on axial depth.

Milling amount compared with 2 Flutes (Ø 2 X EL 6)

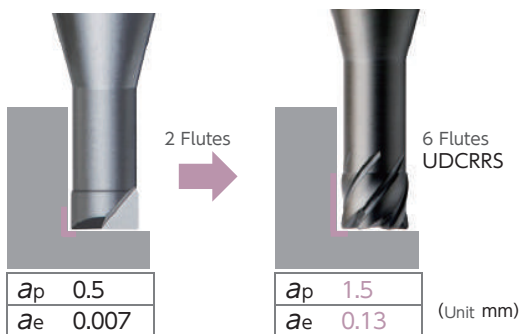

Compared to a tool with 2 flutes, the  $a_p$  is 3 times and the  $a_e$  is 18 times higher.

This shows a significant efficiency improvement.

Cutting material removal volume for each size

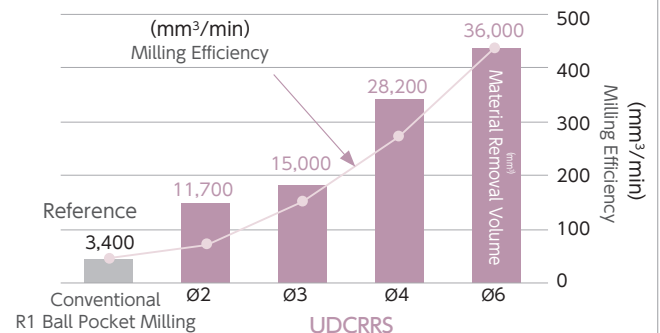

Milling efficiency and material removal volume exceeds the conventional tool.



**UDCRRS Roughing Conditions - Based on Union Tool Europe experiences**

WORK MATERIAL		CEMENTED CARBIDE ( $\geq 87\text{HRA}$ )							
Model Number	Outside Diameter (mm)	Flat milling				Trochoidal milling (side milling)			
		Spindle Speed (min-1)	Feed Rate (mm/min)	ap Axial Depth (mm)	ae Radial Depth (mm)	Spindle Speed (min-1)	Feed Rate (mm/min)	ap Axial Depth (mm)	ae Radial Depth (mm)
<b>6020-020-050</b>	<b>2</b>	20 000	375	0.1	0.8	24 000	2700	1.6	0.02
<b>6030-020-075</b>	<b>3</b>	17 500	375	0.1	1.2	17 500	2300	2.4	0.02
<b>6040-020-100</b>	<b>4</b>	15 000	375	0.1	1.6	15 000	1780	3	0.06
<b>10060-020150</b>	<b>6</b>	10 000	375	0.2	1	10 000	1950	3	0.08

WORK MATERIAL		HARD BRITTLE MATERIALS							
Model Number	Outside Diameter (mm)	Flat milling				Side milling			
		Spindle Speed (min-1)	Feed Rate (mm/min)	ap Axial Depth (mm)	ae Radial Depth (mm)	Spindle Speed (min-1)	Feed Rate (mm/min)	ap Axial Depth (mm)	ae Radial Depth (mm)
<b>6020-020-050</b>	<b>2</b>	20 000	375	0.1	0.8	20 000	375	1.5	0.13
<b>6030-020-075</b>	<b>3</b>	17 500	375	0.1	1.2	17 500	375	2.2	0.19
<b>6040-020-100</b>	<b>4</b>	15 000	375	0.1	1.6	15 000	375	3	0.25
<b>10060-020150</b>	<b>6</b>	10 000	375	0.2	1	10 000	375	4	0.3

WORK MATERIAL		CEMENTED CARBIDE ( $< 87\text{HRA}$ )							
Model Number	Outside Diameter (mm)	Flat milling				Side milling (outside)			
		Spindle Speed (min-1)	*Feed Rate (mm/min)	ap Axial Depth (mm)	ae Radial Depth (mm)	Spindle Speed (min-1)	*Feed Rate (mm/min)	ap Axial Depth (mm)	ae Radial Depth (mm)
<b>6020-020-050</b>	<b>2</b>	10 000	375	0.1	0.8	10 000	1440	1.5	0.02
<b>6030-020-075</b>	<b>3</b>	6 700	375	0.1	1.2	6 700	1610	2.2	0.02
<b>6040-020-100</b>	<b>4</b>	5 000	375	0.1	1.6	5 000	1780	3	0.02
<b>10060-020150</b>	<b>6</b>	3 300	375	0.2	1	3 300	2000	4	0.02

**Roughing with UDCRRS**



**Finishing with UDC 2 Flutes**

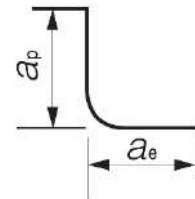

UDCRRS is designed for roughing, use other UDC 2 flutes when finishing.

These milling parameters are based on VF-20, VM-40, VC-70, VU-70 (TAS standard) for Cemented Carbide, and Alumina for Hard Brittle Materials. These are for reference only.

Tool life may differ depending on the type of Cemented Carbide / Hard Brittle Materials.

For best result, fine parameter adjustments may be required, depending on the materials of Cemented Carbide / Hard Brittle Materials; milling Shape and strategy; machine rigidity and spindle capability.



Deep milling on axial depth

**1. For Cemented carbide side milling, please use circular arc with the right trochoid arc R. Avoid “spiral milling” roughing strategies.**

- Trochoid R0.2mm minimum for UDCRRS Ø2, Ø3 and Ø4mm
- Trochoid R0.8mm minimum for UDCRRS Ø6mm

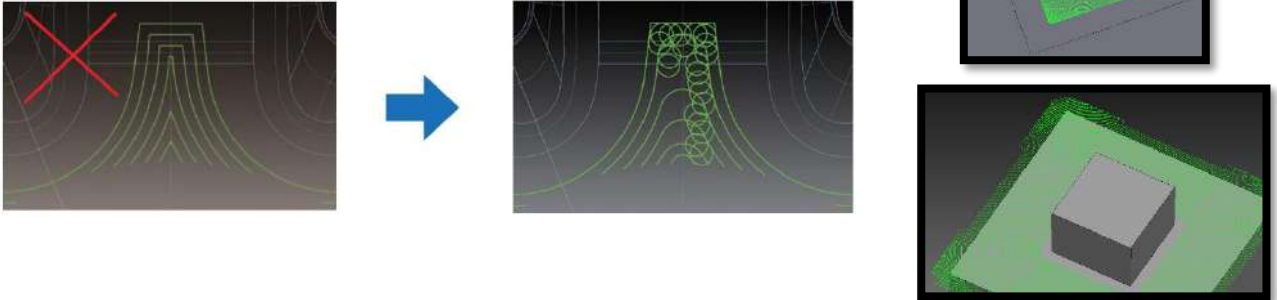

**2. Avoid Z movement for noncutting toolpath during Trochoidal milling.**

**3. Avoid acceleration for noncutting toolpath during Trochoidal milling.**

**4. Be careful with the spindle expansion:**

- Allow few minutes (recommended 10 minutes) spindle warm up when changing a tool and check the Z level of your UDCRRS.
- The spindle, the tool holder and the cutting tool should have the same temperature to avoid expansion during cutting moves.

**5. For a good chip evacuation, please use high pressure air blow from multiple direction**

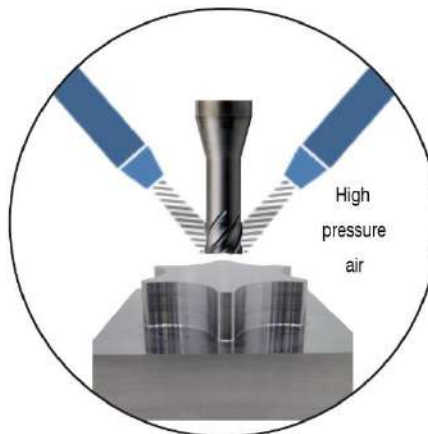

Spindle Speed	15,000 min <sup>-1</sup>
Feed Rate	375 mm/min
$a_p$ Axial Depth	3 mm
$a_e$ Radial Depth	0.25 mm
Coolant	Air Blow
Cycle Time	93 min

Depth 9 mm  
 $a_p$  3 mm  $\times$  3 times

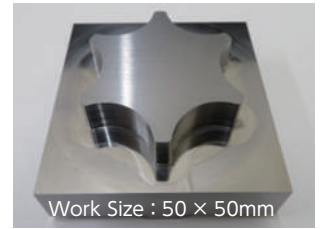
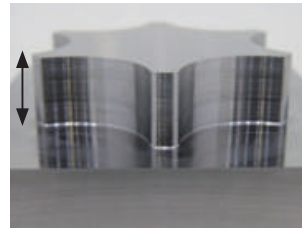

Tool after milling

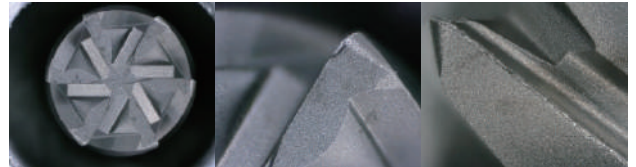

Milling volume 15,953 mm<sup>3</sup> with a single tool in 93 min.  
Tool damage is limited and continuous cutting is possible.

# UPDLRS



1 Flute Binderless PCD Long Neck Radius End Mills for Finishing Cemented Carbide and Hard Brittle Materials

∅0.2~∅2



Material Applications (★ Highly Recommended ● Recommended ○ Suggested)

Work Material																	
CARBON STEELS S45C S55C	ALLOY STEELS SK / SCM SUS	PREHARDENED STEELS NAK HPM	HARDENED STEELS					CAST IRON	ALUMINUM ALLOYS	GRAPHITE	COPPER	PLASTICS	GLASS FILLED PLASTICS	TITANIUM ALLOYS	HEAT RESISTANT ALLOYS	CEMENTED CARBIDE	HARD BRITTLE (NON-METALLIC) MATERIALS
			~ 50 HRC	~ 55 HRC	~ 60 HRC	~ 65 HRC	~ 70 HRC										
															★	●	

## Features

**Binderless PCD**  
Provides excellent machined surface quality due to the sharp cutting edge and optimized edge treatment.  
Maintains excellent dimensional accuracy for a long time due to the high contour accuracy of the cutting edge and the excellent wear resistance of diamonds.

Label Sample



Diameter and Corner R accuracy measurements are printed on the label to support High Precision milling.

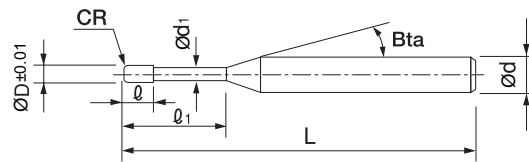

Be sure to confirm the interference between the inclined work piece and the shank part by actual measurement.

Total 12 models

Unit (mm)

Model Number	Outside Diameter ∅D	Corner Radius CR	Effective Length $l_1$	Length of Cut $l$	Neck Diameter $\phi d_1$	Shank Taper Angle Bta	Overall Length L	Shank Diameter $\phi d$	Series
UPDLRS 1002-002-006	0.2	R0.02	0.6	0.1	0.175	16°	40	4	UPDLRS
UPDLRS 1002-005-006		R0.05					40	4	UPDLRS
UPDLRS 1003-002-010	0.3	R0.02	1	0.15	0.27	16°	40	4	UPDLRS
UPDLRS 1003-005-010		R0.05					40	4	UPDLRS
UPDLRS 1005-005-015	0.5	R0.05	1.5	0.25	0.47	16°	40	4	UPDLRS
UPDLRS 1005-010-015		R0.1					40	4	UPDLRS
UPDLRS 1010-005-030	1	R0.05	3	0.55	0.95	16°	40	4	UPDLRS
UPDLRS 1010-010-030		R0.1					40	4	UPDLRS
UPDLRS 1010-020-030		R0.2					40	4	UPDLRS
UPDLRS 1020-005-040	2	R0.05	4	0.55	1.95	16°	40	4	UPDLRS
UPDLRS 1020-010-040		R0.1					40	4	UPDLRS
UPDLRS 1020-020-040		R0.2					40	4	UPDLRS

WORK MATERIAL			CEMENTED CARBIDE			
Model Number	Outside Diameter (mm)	Effective Length (mm)	Spindle Speed (min <sup>-1</sup> )	Feed Rate (mm/min)	a <sub>p</sub> Axial Depth (mm)	a <sub>e</sub> Radial Depth (mm)
1002-002-006	0.2	0.6	40,000	100	0.001	0.001
1002-005-006			40,000	100	0.001	0.001
1003-002-010	0.3	1	40,000	150	0.002	0.001
1003-005-010			40,000	150	0.002	0.001
1005-005-015	0.5	1.5	40,000	200	0.003	0.001
1005-010-015			40,000	200	0.003	0.001
1010-005-030	1	3	40,000	400	0.005	0.003
1010-010-030			40,000	400	0.005	0.003
1010-020-030			40,000	400	0.005	0.003
1020-005-040	2	4	40,000	600	0.01	0.005
1020-010-040			40,000	600	0.01	0.005
1020-020-040			40,000	600	0.01	0.005

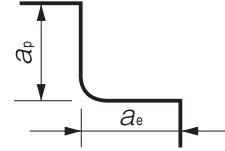

Note:

- Use a machine with high accuracy for stable cutting.
- Non-water soluble coolant recommended. Supply as a mist or external coolant. Take fire prevention precautions to avoid fire hazards caused by sparks igniting during machining or tool breakage.
- Shorten overhang as much as possible.
- Adjust cutting conditions as necessary as machine spec and other conditions may vary.
- These cutting parameters show reference value. Adjust the cutting conditions to the desired machined surface finish.

Milling Example for Finishing  
UDCLRSF / UPDLRS Ø2

Cemented Carbide  
VF-20 (92.5 HRA)

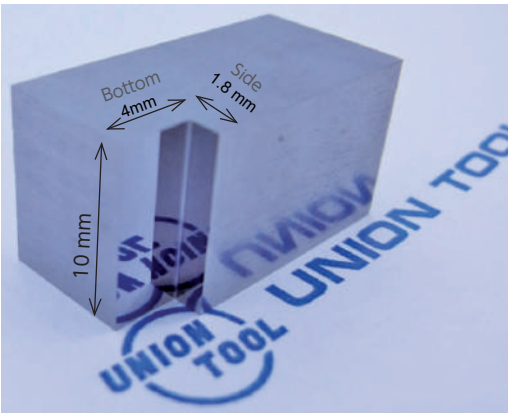

Milling Area : 4 × 10 × Depth 1.8 mm

Work Size : 10 × 10 × 20 mm

After Finishing

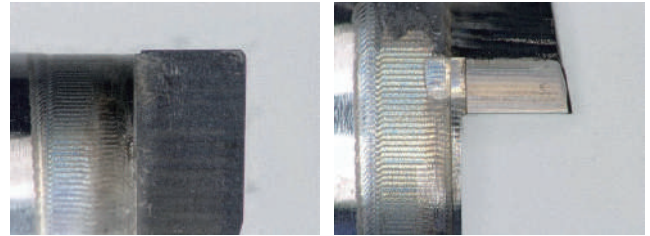

Milling Process	Tool	Spindle Speed (min <sup>-1</sup> )	Feed Rate (mm/min)	a <sub>p</sub> (mm)	a <sub>e</sub> (mm)	Allowance (mm)	Coolant	Cycle Time
Roughing	UDCLRSF 2020-005020 (Ø2 × CR0.05 × EL2)	20,000	400	0.9 × 2 Times	0.01	0.005	Air Blow	54 min
Finishing (Bottom)	UPDLRS 1020-005-040 (Ø2 × CR0.05 × EL4)	40,000	600	0.01	0.005	0		45 min
Finishing (Side)		40,000	400	0.002	0.01	0		52 min

# UDCMX



2 Flute Drills for Cemented Carbide and Hard Brittle Materials

ø0.3~ø7



Material Applications (★ Highly Recommended ● Recommended ○ Suggested)

Work Material																	
CARBON STEELS S45C S55C	ALLOY STEELS SK / SCM SUS	PREHARDENED STEELS NAK HPM	HARDENED STEELS					CAST IRON	ALUMINUM ALLOYS	GRAPHITE	COPPER	PLASTICS	GLASS FILLED PLASTICS	TITANIUM ALLOYS	HEAT RESISTANT ALLOYS	CEMENTED CARBIDE	HARD BRITTLE (NON-METALLIC) MATERIALS
			~ 50 HRC	~ 55 HRC	~ 60 HRC	~ 65 HRC	~ 70 HRC										
																★	●

※Hard Brittle (Non-Metallic) Materials: Ceramics (Alumina, Zirconia,etc.), Glasses and etc.



Offers high quality at a low cost.

Label Sample



#001 ØD5.999

Measured diameter is printed on the label.

Enlarged tip drawing

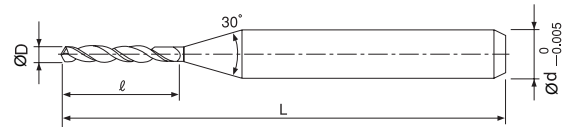

Point Angle : 130°  
Diameter Tolerance : 0/-0.02 (D ≤ 3.5)  
0/-0.025 (D ≥ 4)

※Under-cut type

Total 35 models

Unit (mm)

Model Number	Diameter ØD	Flute Length l	Overall Length L	Shank Diameter Ød	Series	Cemented Carbide		
						Spindle Speed (min <sup>-1</sup> )	Feed Rate (mm/min)	Peck Amount (mm)
UDCMX 2030-030	0.3	3	38	3	UDCMX	28,750	5	0.05
UDCMX 2040-040	0.4	4	38	3	UDCMX	20,000	5	0.05
UDCMX 2050-050	0.5	5	38	3	UDCMX	15,000	5	0.05
UDCMX 2060-060	0.6	6	38	3	UDCMX	11,500	5	0.05
UDCMX 2070-070	0.7	7	38	3	UDCMX	9,000	5	0.05
UDCMX 2080-080	0.8	8	38	3	UDCMX	7,300	7.5	0.05
UDCMX 2090-090	0.9	9	38	3	UDCMX	6,000	7.5	0.05
UDCMX 2100-100	1	10	38	3	UDCMX	5,000	7.5	0.05
UDCMX 2110-100	1.1	10	38	3	UDCMX	4,500	7.2	0.06
UDCMX 2120-100	1.2	10	38	3	UDCMX	4,100	6.8	0.07
UDCMX 2130-100	1.3	10	38	3	UDCMX	3,750	6.5	0.08
UDCMX 2140-100	1.4	10	38	3	UDCMX	3,450	6.2	0.09
UDCMX 2150-100	1.5	10	38	3	UDCMX	3,200	6	0.1
UDCMX 2160-100	1.6	10	38	3	UDCMX	3,000	6	0.1
UDCMX 2170-100	1.7	10	38	3	UDCMX	2,850	5.8	0.1
UDCMX 2180-100	1.8	10	38	3	UDCMX	2,700	5.5	0.1
UDCMX 2190-100	1.9	10	38	3	UDCMX	2,550	5.3	0.1
UDCMX 2200-100	2	10	38	3	UDCMX	2,400	5	0.15
UDCMX 2210-100	2.1	10	38	3	UDCMX	2,300	5	0.15
UDCMX 2220-100	2.2	10	38	3	UDCMX	2,225	5	0.15
UDCMX 2230-100	2.3	10	38	3	UDCMX	2,150	5	0.15
UDCMX 2240-100	2.4	10	38	3	UDCMX	2,075	5	0.15

## 2 Flute Drills for Cemented Carbide and Hard Brittle Materials

Model Number	Diameter ØD	Flute Length ℓ	Overall Length L	Shank Diameter Ød	Series	Cemented Carbide		
						Spindle Speed (min <sup>-1</sup> )	Feed Rate (mm/min)	Peck Amount (mm)
<b>UDCMX 2250-100</b>	<b>2.5</b>	10	38	3	UDCMX	2,000	5	0.2
<b>UDCMX 2300-100</b>	<b>3</b>	10	38	3	UDCMX	1,100	3.7	0.25
<b>UDCMX 2330-120</b>	<b>3.3</b>	12	50	4	UDCMX	1,000	3.4	0.3
<b>UDCMX 2350-120</b>	<b>3.5</b>	12	50	4	UDCMX	910	3.3	0.35
<b>UDCMX 2400-160</b>	<b>4</b>	16	60	6	UDCMX	4,000	6.9	Single-Shot
<b>UDCMX 2420-160</b>	<b>4.2</b>	16	60	6	UDCMX	4,000	7.3	Single-Shot
<b>UDCMX 2450-200</b>	<b>4.5</b>	20	60	6	UDCMX	4,000	7.8	Single-Shot
<b>UDCMX 2500-200</b>	<b>5</b>	20	60	6	UDCMX	4,000	8.7	Single-Shot
<b>UDCMX 2550-250</b>	<b>5.5</b>	25	80	6	UDCMX	4,000	9.6	Single-Shot
<b>UDCMX 2600-250</b>	<b>6</b>	25	80	6	UDCMX	4,000	10.5	Single-Shot
<b>UDCMX 2650-250</b>	<b>6.5</b>	25	80	8	UDCMX	4,000	11.5	Single-Shot
<b>UDCMX 2680-250</b>	<b>6.8</b>	25	80	8	UDCMX	4,000	12	Single-Shot
<b>UDCMX 2700-250</b>	<b>7</b>	25	80	8	UDCMX	4,000	12.4	Single-Shot

Note: (UDCMX)

- Recommend shallower drilling than flute length to promote good chip evacuation.

# UDCT



2 Flute Thread Mills for Cemented Carbide and Hard Brittle Materials

M2~M8



Material Applications (★ Highly Recommended ● Recommended ○ Suggested)

Work Material																	
CARBON STEELS S45C S55C	ALLOY STEELS SK / SCM SUS	PREHARDENED STEELS NAK HPM	HARDENED STEELS					CAST IRON	ALUMINUM ALLOYS	GRAPHITE	COPPER	PLASTICS	GLASS FILLED PLASTICS	TITANIUM ALLOYS	HEAT RESISTANT ALLOYS	CEMENTED CARBIDE	HARD BRITTLE (NON-METALLIC) MATERIALS
			~ 50 HRC	~ 55 HRC	~ 60 HRC	~ 65 HRC	~ 70 HRC										
												○			★	● ※	

※ Hard Brittle (Non-Metallic) Materials: Ceramics (Alumina, Zirconia, etc.), Glasses and etc.



Threading

For thread milling

Label Sample



#001 ØD3.109

Measured diameter is printed on the label.

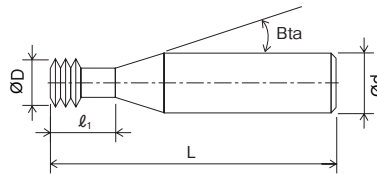

The shank taper angle shown is not an exact value.

Total 10 models

Unit (mm)

Model Number	Thread Diameter M	Pitch P	Tool Diameter ØD	Number of Flutes	Effective Length $l_1$	Shank Taper Angle Bta	Overall Length L	Shank Diameter Ød	Series
UDCT M2-0.4-4	M2	0.4	1.5	2	4	16°	50	4	UDCT
UDCT M2.5-0.45-5	M2.5	0.45	1.9	2	5	16°	50	4	UDCT
UDCT M3-0.5-6	M3	0.5	2.4	2	6	16°	50	4	UDCT
UDCT M4-0.7-8	M4	0.7	3.1	2	8	16°	50	4	UDCT
UDCT M5-0.8-10	M5	0.8	3.9	2	10	16°	60	6	UDCT
UDCT M5-0.8-15					15		60		
UDCT M6-1-12	M6	1	4.6	2	12	16°	60	6	UDCT
UDCT M6-1-18					18		60		
UDCT M8-1.25-16	M8	1.25	5.9	2	16	16°	60	6	UDCT
UDCT M8-1.25-24					24		60		



## 2 Flute Thread Mills for Cemented Carbide and Hard Brittle Materials

WORK MATERIAL					CEMENTED CARBIDE		
Model Number	Thread Diameter	Pitch	Tool Diameter	Effective Length	Recommended Diameter of Hole Before Threading (mm)	Spindle Speed (mm <sup>-1</sup> )	Feed Rate (mm/min)
	M	P	ØD	ℓ <sub>1</sub>			
<b>M2-0.4-4</b>	<b>M2</b>	0.4	1.5	4	Ø 1.6	20,000	3
<b>M2.5-0.45-5</b>	<b>M2.5</b>	0.45	1.9	5	Ø 2.1	20,000	3
<b>M3-0.5-6</b>	<b>M3</b>	0.5	2.4	6	Ø 2.5	20,000	3
<b>M4-0.7-8</b>	<b>M4</b>	0.7	3.1	8	Ø 3.3	10,050	30
<b>M5-0.8-10</b>	<b>M5</b>	0.8	3.9	10	Ø 4.2	8,000	30
<b>M5-0.8-15</b>				15			
<b>M6-1-12</b>	<b>M6</b>	1	4.6	12	Ø 5	6,800	30
<b>M6-1-18</b>				18			
<b>M8-1.25-16</b>	<b>M8</b>	1.25	5.9	16	Ø 6.8	3,500	20
<b>M8-1.25-24</b>				24			

Note: (UDCT)

- Use a machine equipped with helical interpolating functions.
- The radial cutting depth is recommended to cut all at once. Do not cut several times.
- Adjust turning radius amount to meet required internal thread precision.

Note: (All UDC series except for UPDLB&UPDLRS)

- Avoid contact with the coated area of the shank. This will prevent tip vibration and tool jamming in the collet holder.
- Use an inclined or helical approach (Recommended inclination angle: <5 degree).
- Air blow offers longer tool life when milling Cemented Carbide.
- Recommend water soluble coolant for Hard Brittle (Non-Metallic) Materials.
- Protective gear, such as safety glasses and face guards are required when milling.
- Chips / dust generated while milling can have adverse affects on the machine parts if they are not properly evacuated. Take steps to assure proper evacuation.

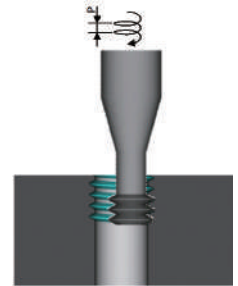



## Advisory for Safe Use of End Mills

Correct application and operation is strongly advised to avoid clogging, abrasion, etc, that could cause serious accidents or injuries. Ignition or sparks generated during milling could lead to fire or extreme damage to the work piece. End Mills are made with very sharp cutting edges and must be handled with extra care.

- Never touch the cutting edge with your bare hands, as this could cause serious injury. Special caution is required when opening the package.
- Dropping the tool could cause breakage or flying debris, leading to serious injury.
- During milling, unexpected impact or shock on the tool could cause breakage or flying debris. Ensure to use protective items such as safety glasses and a face guard.
- For best results, fine parameter adjustment may be required, depending on the materials; milling shape and strategy; machine rigidity and spindle capability.
- Use a machine that has high rigidity and generates a low level of vibration. Recommend setting the runout control value at 5 $\mu$ m or below for the small diameter tools  $\phi$ 1 or below.
- Do not use flammable cutting oils.

---

### U.S. UNION TOOL, INC.

(U.S. HEADQUARTERS)  
1260 N. Fee Ana Street, Anaheim, CA 92807-1817 U.S.A.  
Tel: 1-714-521-6242 Fax: 1-714-521-8642

### NORTHERN CALIFORNIA REGIONAL SERVICE CENTER

(Customer Service, Santa Clara, California)  
1805 Little Orchard Street, Suite 120, San Jose, CA 95125 U.S.A.  
Tel: 1-408-982-0205 Fax: 1-408-982-0320

### UPPER MIDWEST REGIONAL SERVICE CENTER

(Customer Service, Minneapolis, Minnesota)  
155 Bridgepoint Drive, Unit 3 South St. Paul, MN 55075 U.S.A.  
Tel: 1-651-552-0440 Fax: 1-651-552-0435

### TAIWAN UNION TOOL CORP.

No.180, Zhong-Zun Street., 14 Neighborhood, Bin-Hai Vil.,  
Lu-Zhu Dist., Taoyuan City, 338 TAIWAN  
Tel: 886-3-354-3111 Fax: 886-3-354-3110

### UNION TOOL EUROPE S.A.

Avenue des Champs-Montants 14aCH-2074 Marin /  
Neuchatel SWITZERLAND  
Tel: 41-32-756-6633 Fax: 41-32-756-6634

### UNION TOOL (SHANGHAI) Co., LTD.

No.9-10, Lane 385, Gaoji Road, Sijing High New Technology  
Development Zone, Songjiang District, Shanghai, 201601 CHINA  
Tel: 86-21-5762-8577 Fax: 86-21-5762-8436

### UNION TOOL HONG KONG LTD.

Unit 2803 & 05, 28/F, Peninsula Tower, 538 Castle Peak Road,  
Cheung Sha Wan, Kowloon, HONG KONG  
Tel: 852-2370-3012 Fax: 852-2370-2111

### DONGGUAN UNION TOOL LTD.

No.5, Hong Jin Road, Hongmei Town,  
Dongguan City, Guangdong Province 523160.CHINA  
Tel: 86-769-8884-8900 Tel: 86-769-8884-8901  
Fax: 86-769-8884-8296

### UNION TOOL SINGAPORE PTE LTD.

140 Paya Lebar Road #08-17, AZ @ Paya Lebar,SINGAPORE 409015  
Tel: 65-6846-9309 Fax: 65-6846-0197

### UNION TOOL (THAILAND) CO., LTD.

55/73 Moo 15 Bangsaothong Sub-District, Bangsaothong District,  
Samutprakarn 10570 THAILAND  
Tel: 66-2-130-0908 Fax: 66-2-130-0909



<https://www.uniontool.com>



# 0120-60-2620

Price & Specifications are subject to change without notice.